

**BRAKE SYSTEM**



**AN ADVANCED TECHNOLOGY BRAKE SYSTEM**

# CATALOGUE 2005

Indice C du 29/06/2005

BERINGER SA, ZA, F-42940 CHATELNEUF

ISO 9001 registered

Tél : (+33) 4 77 76 82 95

Fax : (+33) 4 77 76 80 09

E-mail : [contact@beringer.fr](mailto:contact@beringer.fr)

# Quality and performance made in France

## BERINGER BRAKING SYSTEMS for motorbikes



- **FLOATING CAST IRON DISCS**
- **CALIPERS 2, 4 and 6 PISTONS machined from solid**
- **SUPERMOTARD KITS**
- **4D AEROTEC® patented 4 disc braking system**
- **MASTER CYLINDER RADIAL AEROTEC®**
- **CLUTCH MASTER CYLINDER RADIAL AEROTEC®**
- **REAR MASTER CYLINDER**
- **SINTERED METAL PADS**



**AEROTEC®  
PATENTS**



# **An advanced technology: the COMPETITION**



**BERINGER is  
2000,2002 and 2003  
Endurance World Champion**

**Adrien CHARREYRE**  
Vice World Champion  
(provisional classification  
June 2005)

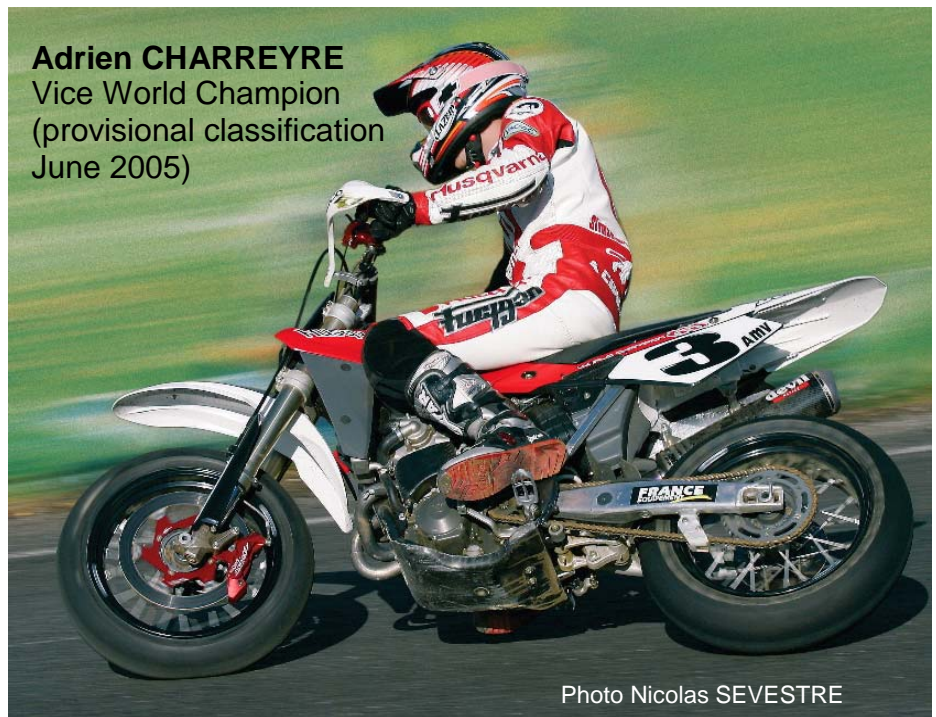

Photo Nicolas SEVESTRE



**BERINGER is 2003 and 2004  
Supermotard EUROPEAN  
Champion**



# BERINGER BRAKES: QUALITY AND HIGH PERFORMANCE

**BERINGER** company has been manufacturing brakes for competition for more than 15 years, in the same spirit of quality and performance. Very quickly the **BERINGER** braking parts have been appreciated by the official teams for their exceptional reliability. This enabled **BERINGER** to enter and stay in the Endurance World Championships, supplying a lot of teams in 12 years and winning the 2000 and 2003 World Champion title with the Phase One Team, and the 2002 title with ZONGSHEN team. This was possible because of a staff of impassionate Engineers who were able to study and develop some new products specific for each use. These patented innovations have allowed **BERINGER** brakes to take a decisive technological advance.

The 4 disc **AEROTEC®** used in Superbike races is a good example, as well as the **AEROTEC®** master cylinders mounted on bearings and which bring an exceptionnal feeling to the riders, or also the famous **AERONAL** discs that became Supersport World Champion I 2000 with the Team Alpha Technik.

But on the other hand, **BERINGER** is also some Engineering on braking system for any kind of vehicle: from VTT to light planes and also cars or scooters or ATV.

Of course **BERINGER** overcomes perfectly the quality with the intention to ensure a total security to the users of the brakes. Several quality registrations are testifying : ISO 9001, UTAC, TÜV.

For **BERINGER** there is no difference between the parts for any rider and race pilots. **BERINGER** braking systems are studied to stand up to the stress of competition. Thus you enjoy the technological advance continuously applied on the parts that you buy.

## Braking systems can be upgraded in 4 stages :

1. replace only **discs + pads**. This will give a considerable improvement in both power and proportional response, but will not cure the disadvantages inherent in the original parts:

- elastic caliper
- pad with restricted friction area
- master cylinder badly progressive and with high hysteresis

2. replace **discs + pads + calipers**. This is technically a better solution because it combines many advantages of the **BERINGER** braking system. In that case the most penalizing part of the braking system is the master cylinder (feeling).

3. replace the all system : **discs + pads + calipers + master cylinder**. This is technically the ideal solution as it allows to even more increase the feeling and to make the most of the power of the **BERINGER** braking system.

4. taking the **AEROTEC 4D** (patented braking system with 2 double discs + specific calipers + specific pads) + **master cylinder**. It is the best braking system which increases also the manoeuvrability of the bike.

*NOTE : Replacement of the original rubber brake hoses by PTFE / stainless braid hoses ("aviation" grade) also represents a significant improvement as it reduces brake lever travel. However, the stainless hoses cannot improve power or proportional response.*

## The BERINGER braking systems:

FINITIONS AVAILABLE	page 4
CAST IRON BRAKE DISCS : classic and AERONAL types	page 4 & 5
CALIPERS 6, 4 and 2 pistons, AEROTEC® 6P and 4P RADIAL CALIPERS	page 6 to 9
AEROTEC 4D : the patented 4 discs braking system	page 10
RADIAL AEROTEC® MASTER CYLINDERS, kit reservoir, braking switch kit	page 12 & 13
SUPERMOTARD: KIT TOP RACE and KIT RACE	page 14 & 15
ACCESSORIES, STICKERS, CLOTHING	page 11

## Parts and prices:

### . Per product :

PADS	page 16
SUPERMOTARD KITS	page 15
RADIAL AEROTEC® MASTER CYLINDERS	page 13
AEROTEC® 4D	page 10

### . Per Motorbike :

APRILIA	page 26	GUZZI	page 26	KTM	page 26
BIMOTA	page 26	HARLEY	page 27	SUZUKI	page 20
BMW	page 17	HONDA	page 18	TRIUMPH	page 25
BUELL	page 27	HUSABERG	page 26	VERTEMATI	page 26
CAGIVA	page 26	HUSQVARNA	page 26	VOR	page 26
DUCATI	page 26	KAWASAKI	page 24	VOXAN	page 26
		SHERCO	page 26	YAMAHA	page 22

## **FINITION of the parts: (concerning Harley, see page 27)**

The hubs of the floating discs are: **BLACK ANODIZED for CLASSIC type**  
**RED ANODIZED for AERONAL type**

The calipers are **RED ANODIZED** for all types.

Other colours are available on orders with an extra price of **FA** per serie of parts, with a 15 days delay.

**WARNING:** - The chrome plated finition is available but with a delay and an extra price of **FB per part**: this covering is strictly reserved for an occasional use. Under no circumstances, water or corrosive products (like removal of snow salt) must not stay on the chrome plating. This would cancel the guarantee. In the same way, chips caused by fine gravel would invalidate the warranty to.

- The polished finition is also available but with delay and an extra price of **AA per part**.

**EACH PART IS DELIVERED WITH AN ASSEMBLY AND GUARANTEE INSTRUCTION SHEET**  
**BRAKING PARTS ARE HIGH SECURITY ELEMENTS;**  
**YOU MUST READ IT COMPLETELY AND GIVE IT TO THE CUSTOMER.**

**The discs are in original diameter except specifications.**  
**The calipers are mounted in original place except specifications.**  
As the connection from the hose to **BERINGER** Calliper is made lower, it is often necessary to to put a longer hose.  
All the calipers are delivered with the **BERINGER** sintered pads (ABE approval).  
Drawings and photos are not contractual; they can be modified in the constant purpose of improving.

# TÜV approved

## ISO 9001 REGISTERED

## **CAST IRON FLOATING BRAKE DISCS**

**For several years BERINGER has been developing a range of very high performance cast iron floating brake discs. These discs combine all the important notions to ensure an efficient and constant braking in every circumstances.**

The braking surfaces (outer ring of the disc) are entirely CNC machined ensuring an accuracy far superior to that of the stamped stainless discs fitted by motorcycle manufacturers . The material used (gray cast iron) is universally used by all the "high-performance" manufacturers. However, **BERINGER** has considerably developed this material in its chemical composition, casting processes and heat treatments, to give **BERINGER** discs their exceptional performance qualities, widely recognized in racing . The specific structure of our cast iron allows an extremely fast dissipation of the heat generated by the contact with the pads, resulting in a better balanced temperature distribution through the disc, between the surface and the inner metal .This dissipation is better than can be obtained with any other material (steel or stainless). To be more precise, although the average temperature of a steel disc or a cast iron disc will be identical (for a given braking situation), the maximum temperature in the cast iron disc will be lower, due to the better distribution between the surface and the inner metal. Also, the hot distortion of a disc is due to the difference between surface temperatures, resulting in uneven expansion of the disc (expansion is proportional to temperature). Thus, the steel or stainless disc becomes warped and conical, resulting in vibration and lower efficiency, and even going as far as cracking. This problem is non-existent in **BERINGER** cast iron discs.

Thus, the cast iron braking surface remains perfectly plane, resulting in constant braking in all conditions (hot, cold, beginning or end of braking), while accepting far higher temperatures than stainless discs. This increases the braking power available by more than 40%. The coefficient of friction of our cast iron, due to its very fine grain, is also much better, requiring less pressure on the pads, for a given deceleration, than any other material (steel or stainless).

The braking surface on **BERINGER** discs is subject to very little wear, resulting in a very long lifetime in normal road use, and more than a season of competition (endurance racing) with the **AERONAL** Racing.

**BERINGER** brake discs are available in two types to answer to any kind of use:

- **the CLASSIC discs**
- **the AERONAL discs**

# CLASSIC DISCS

The aluminium alloy brake hub is machined from the solid is given a surface anodizing treatment, and is in contact with the 12 studs in special low-friction steel. The initial play in the floating disc (necessary for best performance), remains constant throughout its working life and even beyond.

These discs have drilled braking surface for road or sport use. In fact the holes drilling allows the use of organic pads (or sintered metal pads).



**For a race use in competition on circuit, it is highly recommend to use the AERONAL disc (see following page)**

Classic discs on Harley Bike

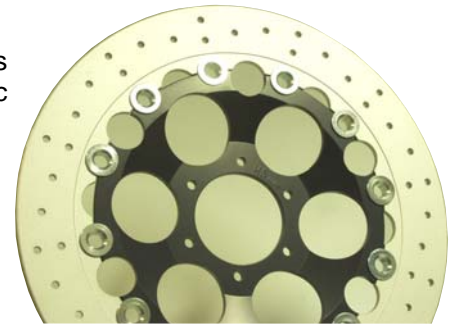

# AERONAL CAST IRON FLOATING DISCS

## 1-CAST IRON : THE BEST MATERIAL FOR BRAKING DISCS

Universally used in car races (F3000, GT, Rallyes) and by all the "high-performance" disc manufacturers, the cast iron allows a faster dissipation of the heat than the steel and stainless used for the original discs of the bikes (because of the lower cost). It is also better heat-resistant. BERINGER has developed a gray cast iron alloy and heat treatments that assure **a total reliability** of the discs even in very hard conditions. The cast iron rotors are covered with anticorrosion "aluminium plasma".

## 2- A 20% SAVING OF WEIGHT :

The disc can reach much higher temperatures and can be used with sintered metal pads, thanks to **narrow braking surfaces without holes**, associated to new heat treatment. The hub has been manufactured out of a **highly performant aluminium alloy**, used in the aeronautics.

## 3- LESS CONSTRAINTS :

Thanks to an exclusive system **binding the hub and the braking surface with setting over the supporting areas**, the constraint at this very place is divided by two, and the working life of the disc increases.

## 3- GAIN OF MANOEUVRABILITY :

The **gyroscopic inertia is appreciably reduced** by the use of narrow braking surfaces and 6 studs instead of 12, upgrading the manoeuvrability of the bike.

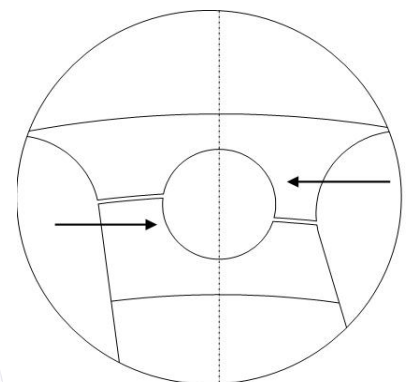
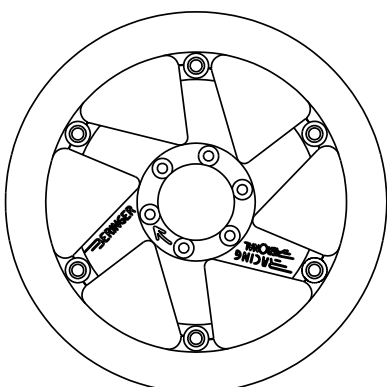
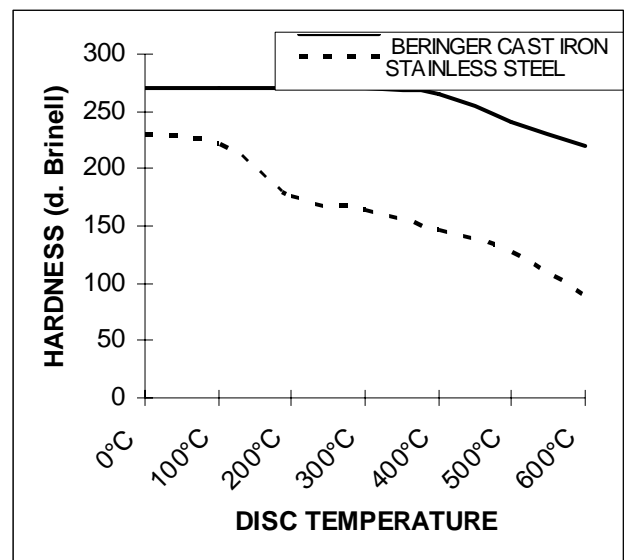

# CALIPERS : a high technology product

All **BERINGER** brake calipers are :

- **Machined from aeronautic aluminium billet** (better resistance to deformation in high temperatures)

- **Machined on CNC machines** ( precision and quality with aeronautic manufacturing process)

This optimized manufacturing process allows the very best materials to be used (unlike cast calipers) together with closely controlled material thicknesses, so that these calipers are actually lighter than OEM calipers fitted by motorcycle manufacturers.

The pistons are stainless alloy, which isolates the caliper from the heat generated by the pads (stainless alloy only conducts one thirteenth of the heat conducted by aluminium) and also eliminates any possibility of corrosion. The setting over of the pistons against the pressure center of the pads allows a constant and regular wear of the pads.

The **EXCEPTIONAL RIGIDITY** of these calipers is partly due to the machining technique used, and partly due to the method of assembly of the two parts of the calliper : this minimizes the longitudinal opening of the calliper, when working. The consequences are : incisive braking with a very short response time, constant lever and constant lever travel.

**Each type of caliper is specifically designed for each motorcycle. The caliper is mounted directly on the fork without adapter and so ensures a perfectly rigid fastener very close to the fork sleeves.**

The original master cylinder is suitable, despite its disadvantages, because the great gain of rigidity and precision of the caliper minimizes the brake fluid volume required for braking.

**BERINGER calipers are available in several types to answer to any kind of use :**

**BERINGER 6 piston calipers** : the 6-PISTON technique enables a small diameter to be used (27 mm), which reduces the caliper width (60 mm), while maintaining excellent piston guidance inside the cylinders (good guidance is the result of a high piston height/bore ratio).



**BERINGER 4 piston calipers** They have a classic guiding of the pads. Intended for small and middle-engined sport bikes, for Supermotard or for bikes which does not need to dissipate great braking energy, these calipers represent an economic option to the 6 piston calipers while maintaining excellent quality, weight and performance characteristics .



**BERINGER 2 piston ultra light calipers: 305g** are intended for competition or sport bikes. They are granted the technological innovations of his cousins with 4 or 6 pistons. Their main use is replacing the rear calipers to improve the rear braking on to the maximum of its possibility:

- rear braking for competition (superbike and endurance)
- rear braking for sport, highway and tuned bikes
- front braking for race scooters
- direct mounting on fixing with center distance of 84mm (as italian bikes) **PRICE : MCR**



**AEROTEC® type:** The **AEROTEC® caliper** was developed from the knowledge acquired from different competitions in which Beringer has been involved. Thanks to innovative patents and technical solutions, this caliper has the advantage of reacting more quickly (reduction of hysteresis) and not causing taper wear of brake pads. Performances are better, but this is not the only advantage. They bring an exceptional feeling to the braking. See the characteristics page 7. You will find the AEROTEC® technology in :

- **The AEROTEC® 6 piston calliper (with two pads)**
- **The AEROTEC® radial 4 piston caliper**

The 6 piston AEROTEC type is available for the last applications and the Supermotard bikes and will progressively replace the 6 pads famous BERINGER calipers. The new radial 4 piston calipers present the same specifications as the 6 piston AEROTEC® calipers, only the fixing on the fork is a radial type.



## Technical innovations:

- **Reduction of hysteresis**

Thanks to the **AEROTEC**® patented system of chrome-plated guides for the brake pads and their location in a neutral zone where there is no deformation, hysteresis is dramatically reduced.

- **More aggressive and stronger**

Only 16.5 bars are necessary to reach an equivalent torque, against 20 with another caliper. A gain of 20%!

- **Improved control**

Actually compared to another racing caliper, the error of control is reduced to 17% against 53%. In order to reach again the same torque after having released the brake, 14 bars are necessary with **BERINGER** caliper and 12 bars with the other systems.



## A better behaviour :

- **No pad taper:**

The **AEROTEC**® system avoids the stantwise wear, even when the pads are new or worn.

- **A better feeling**

As the pads are not taper used, they do not touch the disc when you release the brake. There are no more vibrations.

- **A longer brake pads life**

Due to the optimisation of the pad wear, life time, efficiency and endurance are improved.

- **A constant braking feeling**

The brake feeling is constant whatever the pad's wear is or the temperature conditions are.

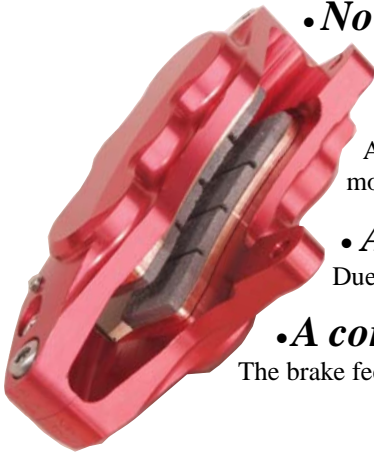

### Brake pads guide : the **AEROTEC**® patent

The patented system of chrome-plated guides for the brake pads greatly reduces hysteresis of the caliper. The brake pads are mounted on supports equipped with two lugs. These lugs slide easily on the chrome-plated guide bars, even during intensive use under difficult conditions. Thanks to this system and their location in a neutral zone where there is no deformation, hysteresis is dramatically reduced. Only 16.5 bars are necessary to reach an equivalent torque, against 20 with another caliper. A gain of 20%! Actually compared to another racing caliper, the error of control is reduced to 17% against 53%. In order to reach again the same torque after having released the brake, 14 bars are necessary with **BERINGER** caliper and 12 bars with the other systems.

In this way (see graph), when pressure is put on the brake lever, with a **Beringer** caliper a torque of 17 mdaN can be obtained with a pressure of 66 bars, instead of 80 on a standard system.

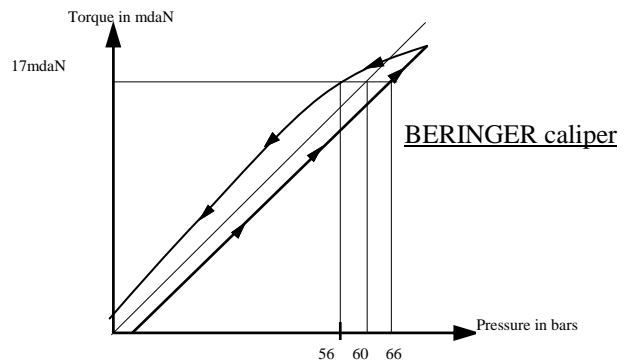
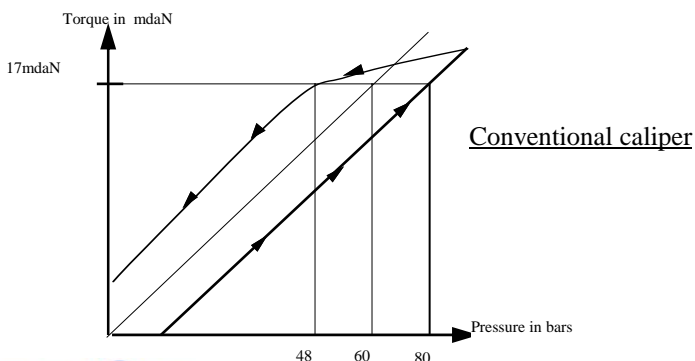

When the lever is released, to obtain these same 17 mdaN, 56 bars are needed with **Beringer** against 48 with a traditional system: the control error is reduced to 17% against 53 %

Machined on CNC from a billet of an aeronautic high performance alloy used on the wings of supersonic planes.

AEROTEC® chromium-plated guides of the pads

Important chamfer allowing an easy removal of the wheel or the caliper **without removing the pads.** (wheels 17" and 16.5")

Low head screw included into the body.

Direct mounting on original or racing fork for the 6 piston and the 4 piston radial calipers.  
**No adapter plate**

Chamfer which provides play between the caliper and the spokes.

The AEROTEC® patented system to guide the pads on the chromium-plated and ground guides allows to reduce considerably the hysteresis of the caliper.

Special designed pads sliding without friction on the chromium-plated guides.

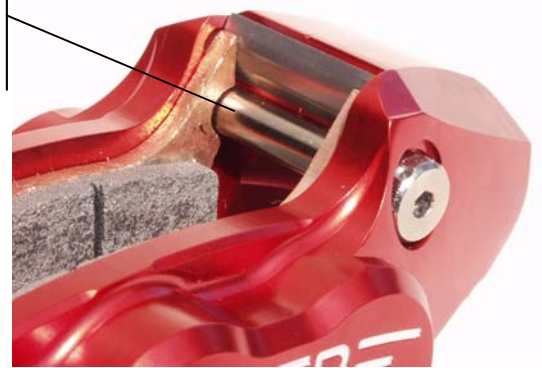
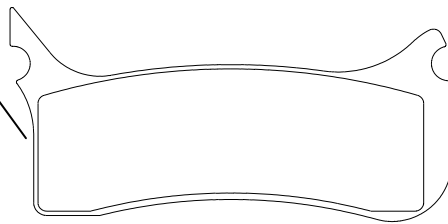



# AEROTEC® ENDURANCE CALIPERS



In 1997 BERINGER was innovating by creating a caliper studied and developed with input from major racing teams who already used BERINGER braking parts. In 2002, BERINGER has developed the **ENDURANCE AEROTEC® 6P CALIPER** to increase its performance (15 % more rigidity, mounting on forks with 90mm and 40 mm center distances).

This caliper, combined with the BERINGER Aeronal disc remains the must for over half of the Superbike and Superproduction-class field in the World Endurance Championship. Since 2004, it is also



available in **4P AEROTEC® RADIAL ENDURANCE** version. These two calipers are specifically designed with the constraints of long distance racing in mind and features :

## direct mounting on original and "racing" forks

## staggered titanium pistons with magnets :

→ saving of weight

→ constant and plane wear of the pads (compensation angles and patented AEROTEC® guides)

→ Improved thermal insulation between pads and pistons as titanium is twice less heat conductive as stainless steel which allows a temperature reduction of 20 degrees Celsius which in turn reduces the risk of brake fluid boiling.

→ pads remain in contact with the magnet-equipped pistons during wheel changes (the setting of the magnets allows to limit the thermal flux)

## one piece racing 'endurance' pads, 12mm thick

→ improved pad life and longer stretches between pad changes



## disc guiding into the caliper when installing the wheel

→ eliminates the need for chamfering the lower edge of the pads thereby increasing the available braking surface and pad life

lower pad stops → the built-in ridge in the caliper allows to drop the pads in while ensuring a perfect positioning each time

## special section making easier the moving back of the front wheel

- The ENDURANCE AEROTEC® 6P CALIPER is available with two center distances: 40mm and 90mm
- and the 4P AEROTEC® RADIAL CALIPER is available with 108mm x 22mm

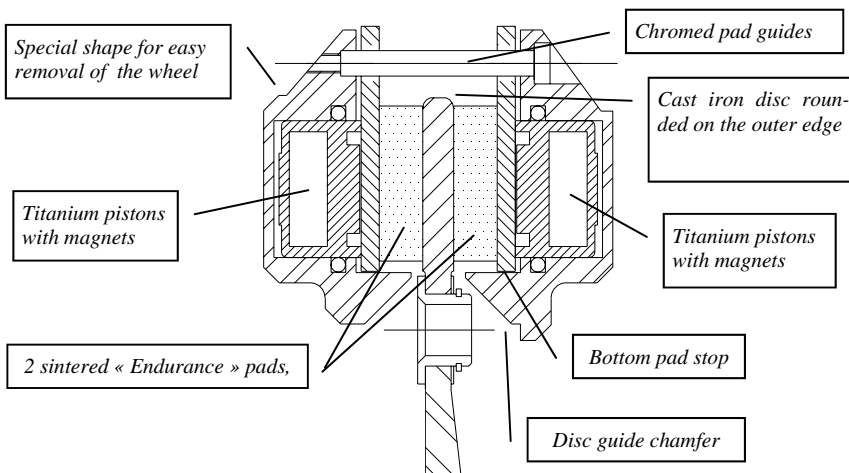

## **SPECIAL AFTER-SALE SERVICE FOR BERINGER ENDURANCE PARTS:**

- complete overhaul in plant of the calipers, master cylinders and discs: disassembling, test, adjustment, replacing of worn parts, rebuilding, test
- individual help, advices
- help during races

**Ask for our special ENDURANCE CATALOGUE**

# 4D AEROTEC® BRAKING SYSTEM with 4 discs

**The purpose of the 4D AEROTEC system :**  
**To decrease the gyroscopic effect and the weight while increasing the power.**



## THE ADVANTAGES OF THE QUADRUPLE DISQUE:

- **The gain of power** compared to a single cast iron Ø320 disc is 20% which allows to the pilot to shorten significantly the braking distances. Some comparative tests have shown the evidence of this gain as well as a lower temperature of the discs.
- **The gain of manoeuvrability** : The gyroscopic inertia of the quadruple disc is **3 times less** than the Ø320 discs and **30% less** than carbon discs : it represents the decisive advantage of this system. For example the time spent into a chicane or the time necessary to enter on angle is highly reduced.
- **The saving of weight** is big compared to the standard systems  
 CAST IRON DISC Ø320 weight: 1950 g      QUADRUPLE DISQUE Ø230 weight 1460 g  
 The **980 g saved** in non suspended weight allow to improve the grip of the front wheel
- **A much longer working life** As a matter of fact, the tests have shown a tiny wear of the system which allows to consider a **working life equal to a race season.**

The entire AEROTEC 4D system includes :

- **2 floating double discs**
- **2 4 piston calipers AEROTEC 4D with special sintered metal pads**

Each kit is especially designed for each bike and uses the same centre line distances as original parts. Thus the mounting is as easy as in the case of original parts, without any risk of mistake.

*Caution: this system is not designed for long Endurance races but is very interesting for qualifying.*

External pads mounted on AEROTEC guides (World patented)

Static central pad with two sides

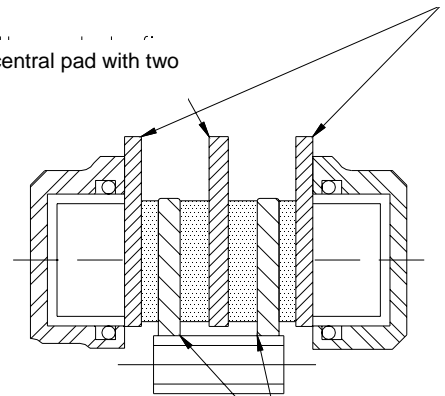

Two semi-floating discs Ø230mm

The 4D AEROTEC® system is directly mounted on following HYPERSPORT bikes

MOTORBIKE	KIT part n°	Price
YAMAHA R1 – YAMAHA R6 –03	D4Y1	QD
HONDA VTR SP1	D4H1	QD
HONDA 900CBR 2000-	D4H2	QD
SUZUKI GSXR 600, 750 -2000, 1300 Hayabusa, 1000TL	D4S1	QD
SUZUKI GSXR 600 2000-, 750 2000-, 1000 2000-2003, SV 1000	D4S2	QD
DUCATI all types after 98 (with original Ø320mm disc, 65mm center distances caliper)	D4D1	QD
APRILIA all types with original Ø320mm disc, 65mm center distances caliper)	D4D2	QD
KAWASAKI ZX7R 96-, ZX12R(original Ø320mm disc)	D4K1	QD
KAWASAKI ZX9R 2000- (original Ø310mm disc)	D4K2	QD
Pads 4D for 2 calipers (6 pads)	1027S 1027R	AP



# ACCESSORIES - EQUIPMENT - STICKERS - CLOTHING

**COLOUR SAMPLE** of available colours and finitions for the disc hubs and the calipers. It is made of aluminium rounds with following finitions : red, purple, blue, yellow, titanium, silver anodised and chromed. **PRICE: AA**



## DISPLAY

in aluminium, allows to show a disc and a caliper. Engraved **BERINGER**. **PRICE: AA**



## STICKERS

**BERINGER** size 15x3cm **PRICE: AD**



## LOGO BERINGER SELF ADHESIVE

Only letters

- Big (white or blue) 30x9cm
- Small (white or blue) 10x3cm

**PRICE: AF**  
**PRICE: AE**



## EMBROIDED BADGE

thermo-adhesive to put on cloths 14x4.5cm **PRICE: AG**



## TEE SHIRT

Dark blue  
Front and back printed  
(big one on the back)  
M L XL  
**PRICE: AT**

## CAP

Dark  
Front embroidered  
**PRICE: AT**



## TEE SHIRT for girl

black  
Front printed  
S M  
**PRICE: AU**



## EMBROIDED POLO

Dark blue  
Front and back embroidered  
M L XL  
**PRICE: W**

# RADIAL MASTER CYLINDERS



# CABLE CLUTCH

These new **BERINGER** brake and hydraulic clutch **MASTER CYLINDERS** were developed for Supermotard, Enduro, Moto-Cross, Sport bikes.

They are very compact and very light (270g). Fully machined from solid using a three bearings system and covered by the AEROTEC® world-wide patents, they bring exceptional feeling. Easy to adjust for reach and with lever finger grips (or plain lever) will provide the ultimate performance. They find a place easily under the hand guard and the overstroke of the piston is individually adjusted with accuracy in the factory.

(see the complete range following page)

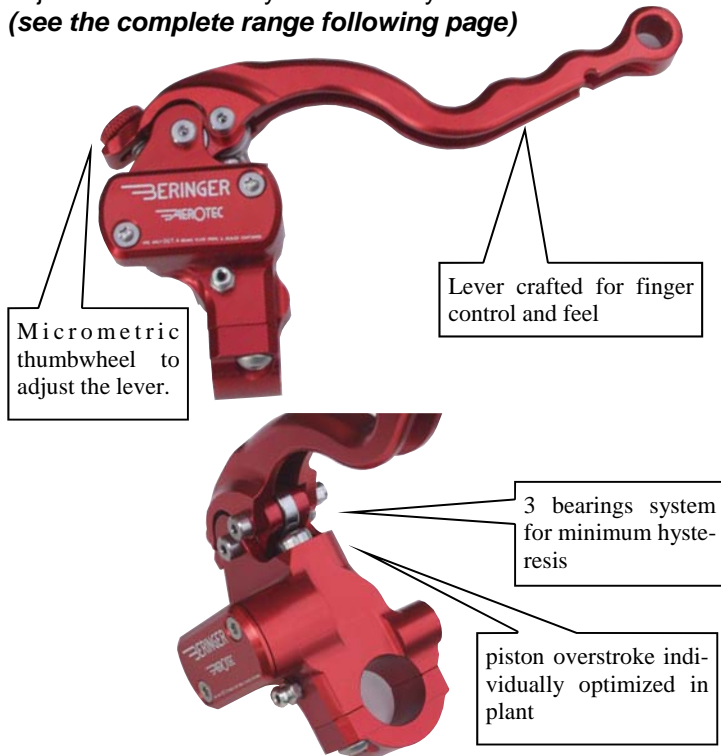

## MAITRE CYLINDRE BERINGER RADIAL AEROTEC® BREVETE

By reducing friction in the lever and piston movement, this brings the actual balance error down to **only 7% !**

An excellent result compared to classical radial master cylinder (see the following graph).

In the quest to improve braking performance it has been normal to

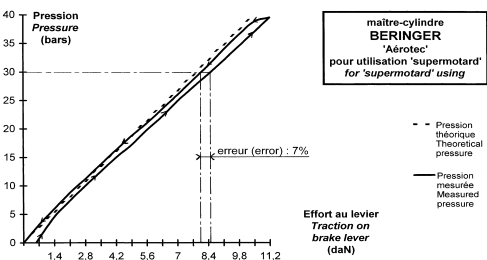

change the master cylinder to a classical radial type. However, when you view this graph it is immediately noticeable that between the application and release of the lever, there can be up to **57% balance error** leading to inferior braking performance.

# NEWS

## AEROTEC® CABLE CLUTCH Same design as the master cylinder

Actually available this new cable clutch was designed with the AEROTEC® system, using a two bearings system which offers an excellent feeling and a reduction of load when unclutching. It presents the same design as the brake master cylinders range allowing to have symmetrical brake and clutch levers.

It amounts on Japanese bikes as well as Enduro, Cross and Supermoto bikes that have a Ø10mm cylindrical cable terminal.

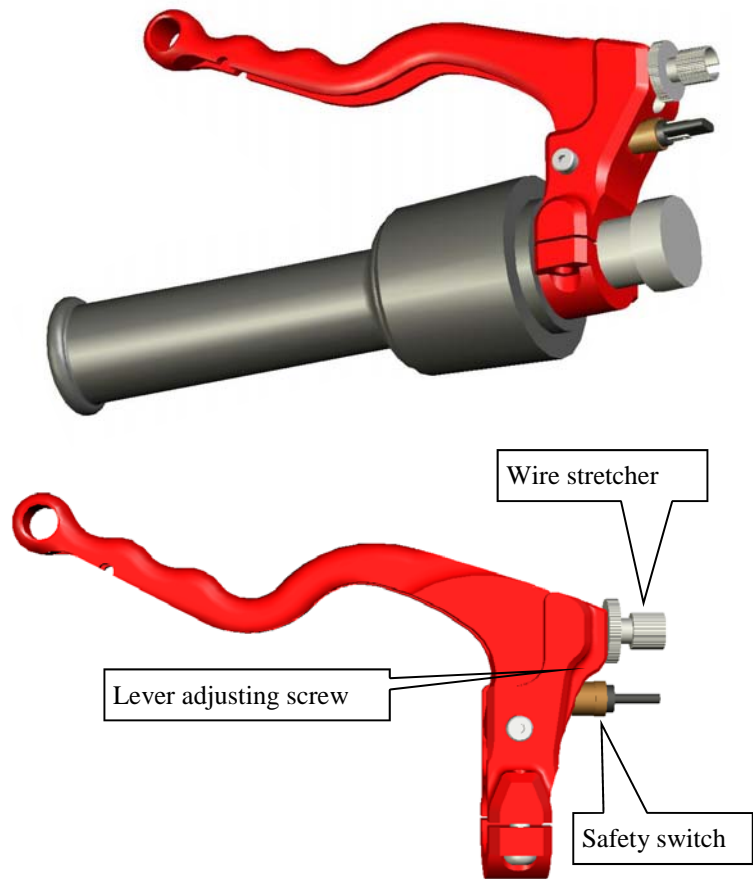

Available with three types of lever :

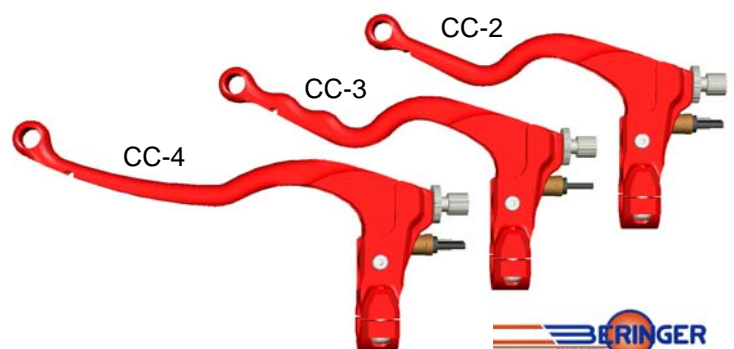

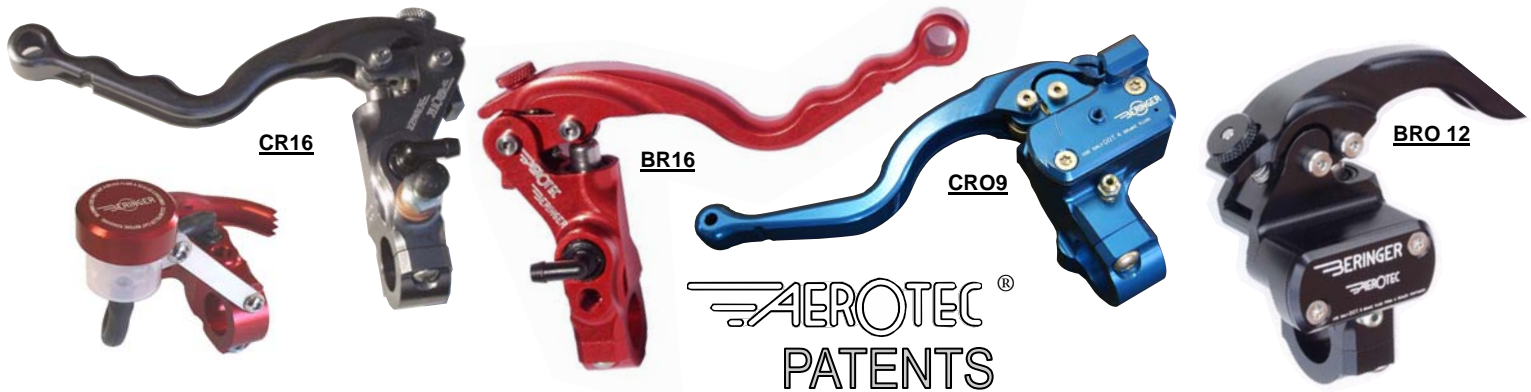

PARTS	Part n°	Use	Price
RADIAL AEROTEC® <b>brake</b> master cylinder	BR 12	For 1 caliper 4 or 6 piston (ex: supermotard) and ATV	MC
RADIAL AEROTEC® <b>brake</b> master cylinder	BR 16	For 2 calipers 4 or 6 piston or 4D système	MC
Hydraulic <b>clutch</b> master cylinder RADIAL AEROTEC®	CR12	For DUCATI and APRILIA	MC
Hydraulic <b>clutch</b> master cylinder RADIAL AEROTEC®	CR16	For other bikes	MC
<b>Brake</b> master cylinder left RADIAL AEROTEC® for scooters	CR12	for scooters	MC
KIT RESERVOIR (small reservoir + engraved solid aluminium cap with same anodized colour as the master cylinder with logo BERINGER+ hose+ stainless steel bracket + aluminium spacer + bolts)	BO1	For BR12, BR16 and other master cylinders	Y
RADIAL AEROTEC® <b>brake</b> master cylinder with included reservoir (without brake fluid gauge)	BRO-12	for 1 caliper 4 or 6 piston, for Supermotard and ATV	MCO
RADIAL AEROTEC® <b>brake</b> master cylinder with included reservoir (without brake fluid gauge)	BRO-10	for 1 BERINGER caliper 4 piston (axial fixing) and for OEM Enduro/Cross caliper	MCO
kit radial hydraulic <b>clutch</b> , included reservoir (without fluid gauge), including o'ring seal for clutch cylinder ( <b>to be used with DOT4 fluid</b> ), specific grease and instructions	CRO-9	for HUSABERG and HUSQVARNA	MCC
Braking and clutch switch kit	CS1	For BR, CR, BRO, CRO	AG
Cable clutch AEROTEC® CC-2 (lever 2 fingers) or CC-3 (lever 3 fingers) or CC-4 (long lever)			MCR

## 12.7 ultra-light rear braking master cylinder : 74g

**This oscillating master cylinder is entirely mounted with ball ends**

**(aeronautical quality)** Part n°: MC12.7 x 22

Weight without ball ends : 74g

Diameter of the piston: 12.7 mm.

Piston travel: 22 mm.

Thread type of the connections (feeding and exit are the same): M10x1

Diameter of the ball end bores : 6 mm (you can have ball bearings ball end)

Ball end rods: M6x0.8 (male).

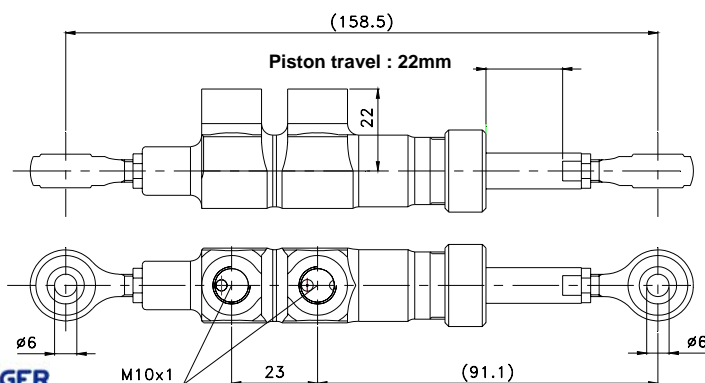

Part	Part n°	Price
Rear master cylinder 12.7	MC12.7x22-6	MCR



**This master cylinder is also made to be mounted in serie with another master cylinder (for example : thumb master cylinder).**

# SUPERMOTARD BRAKING KITS

TÜV approved

ISO 9001 registered

## DIRECT MOUNTING : NO BRACKET:

4 and 6 piston BERINGER calipers are machined from solid on CNC especially for a direct mounting on the fork, without adapter plate. The AERONAL discs are designed the same way for a direct mounting on the wheel, replacing the original ones.



## KIT RACE :

- 4 PISTON CALIPER
- AERONAL FULL FLOATING DISC
- Semi-racing SINTER PADS

PRICE: SR



## KIT TOP RACE :

- 6 PISTON AEROTEC® or 4 PISTON RADIAL AEROTEC® CALIPER
- AERONAL FULL FLOATING DISC
- RADIAL AEROTEC® MASTER CYLINDER BR12-17.5 or BRO-12
- KIT RESERVOIR
- RACING BRAKE HOSE
- Semi-racing AEROTEC® PADS



4P radial or 6P AEROTEC® CALIPER



BR12 + RESERVOIR  
or  
BRO-12  
(reservoir included)







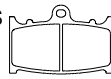

PRICE: ST

# SUPERMOTARD BRAKING KITS

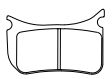
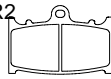
MOTORBIKE		KIT TOP RACE part n°	KIT RACE part n°
HONDA	250CR, 450CRF, 500CR 95-	TRH01	RH01
HONDA	400XR, 600XR, 650XR	TRH02	RH02
HONDA	250CR, 450CRF, 500CR 2004	TRH03	RH03
SUZUKI	400DR, DRZ 450RMZ	TRSU1 TRSU2	RSU1 RSU2
KAWASAKI	250KX + KXF	TRKA1	RKA1
YAMAHA	YZ and WR, YZF and WRF : all types after 1998	TRYA1	RYA1
KTM	Enduro all types and SM -1999		RKT3
KTM	1999—2003	TRKT1	RKT1
KTM	enduro 04-05	TRKT1	RKT1
	Duke 2 et SM 2004	TRKT2	
	SMR 2005	TRKT4 (with 4P radial AEROTEC®)	
HUSQVARNA	All types after 2000	TRHA1	
HUSABERG	All types -04	TRHG1	RHG1
	SM 05	TRKT4 (with 4P radial AEROTEC®)	
SHERCO	SM	TRSH1	
VERTEMATI	All types	TRVE1	RVE1
VOR	All types	TRVO1	RVO1
GAS GAS	Enduro	TRGG1	RGG1
CCM	Enduro	TRCC1	RCC1

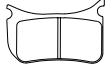
**With your order of Top Race Kit, give us the dimension of the hoses. Other types: please ask us**

BERINGER sintered metal pads			
USE	BERINGER 4 piston caliper	BERINGER AEROTEC® 6 piston caliper	BERINGER RADIAL AEROTEC® 4 piston caliper
ROAD/ COMPETITION	<ul style="list-style-type: none"> <li>• Sport riding on normal roads</li> <li>• Occasional competition only</li> <li>• Wet and slippery racing conditions</li> </ul> 2654 S  U (price of 1 pair)	1100 S  Y (price of 1 pair)	1200 S  Y (price of 1 pair)
COMPETITION	<ul style="list-style-type: none"> <li>• Only for races (<u>absolutely prohibited on the road</u>)</li> </ul> Very good attack, very good behaviour when hot.           2654 R2  V (price of 1 pair)	1100 R2  Z (price of 1 pair)	1200 R2  Z (price of 1 pair)
COMPETITION	<ul style="list-style-type: none"> <li>• Only for races (<u>absolutely prohibited on the road</u>)</li> </ul> Very good attack, very good behaviour when hot.	<b>1220 R2 For FTE 4P RADIAL CALIPER</b> ZR (price of one pair) 	



















## spare parts for SM kits

- |  |  |  |
|--|--|--|
| <ul style="list-style-type: none"> <li>• 4 piston caliper with pads price : S</li> <li>• 4 P radial AEROTEC® caliper price: P</li> <li>• Cast iron AERONAL disc price : F</li> <li>• Spare hub with floaters kit price : DA</li> </ul> | <ul style="list-style-type: none"> <li>• RADIAL AEROTEC® master cylinder and hydraulic clutch price : MC</li> <li>• Kit reservoir, anodized aluminium cover, bolts, hose, bracket price : Y</li> <li>• Cap from solid aluminium, anodized, engraved price : AU</li> <li>• AEROTEC® 6 piston caliper with pads price : P</li> </ul> | <ul style="list-style-type: none"> <li>• Brake hose 125mm or 140mm or 155 mm price : Y</li> <li>• Repair kit for 6P or radial 4P caliper price : AH</li> <li>• Repair kit for 4P caliper price : AJ</li> <li>• Repair kit for master cylinder BR12 or BR16 price: MCK</li> </ul> |
|--|--|--|

## FINITION of the parts

All aluminium parts are **available with red anodized treatment**. Other colours are available **with an extra price of 12.50€ per set and a 15 days delay** (black, purple, blue, yellow, titanium, silver). It means that calipers, hubs of the discs, master cylinders, covers of the reservoir are anodized treated .

# BERINGER SINTERED METAL PADS

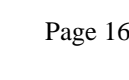
	MOTORBIKE	Part n°	Price 1 pair
	<b>HONDA</b> VFR400R, NTV 650, VFR 750 R 88-93, RC 30,NR 750, RVF 750 RC 45, CBR 900RR Fireblade 92-97, CB 1000 Big One 93-, 1000VTR, 1300CBX-4 97-	<b>2245</b>	V
	<b>HONDA</b> XLV 600 Transalp 91-93, NX 650 Dominator, XR.V 650 Africa Twin, 750 VFR -88, 1000 CBR -88, GL 1500+X <b>CAGIVA</b> 900 Elephant I.E. 91-	<b>2310</b>	U
	<b>HONDA</b> CB 400N, CBR 400 R, CBR 400 F, VFR 400 R, CB 450 S, CBR 600F -94, NTV 600 Revere, VT 600 C 89-91,XRV 750 Africa Twin 90-92, VT1100C Shadow 87-93,	<b>2252</b>	U
	<b>YAMAHA</b> SRX 600 90-, FZR 750 R 87, TDM 850 , TRX 850, FZR 1000 87-89, FJ 1200 88- + ABS 91-93, XJR 1200 94-, XVZ 1300,1300 XVZ Royal Star	<b>2253</b>	U
	<b>YAMAHA</b> YZF 750R 93-97, FZR 1000 94-95 <b>TRIUMPH</b> original 6 Piston caliper	<b>2254</b>	W
	<b>SUZUKI</b> GSXR 750W ,T,V 94-99, GSXR 1000 01-, TL 1000RW, GSXR 1100 93-97, GSF 1200Bandit, GSXR 1300 Haya-busa <b>KAWASAKI</b> ZX6R 600 750 900 Ninja, ZRX 1100 96-2000, ZRX 1200, ZX12R 2000-	<b>2255</b>	W
	<b><u>WARNING : 2255R : ABSOLUTELY PROHIBITED ON THE ROAD</u></b>	<b><u>2255R</u></b>	WR
	<b>HONDA</b> RS 125 R, CBR 400RR, CB 500 94-96 , VT 600 C 93-, NTV 650 Revere, 600CB Hornet +S 98- , 600 CBR 95, CB 750 N Seven Fifty 92-, VFR 750F 88-98, PC 800 89-97, VFR 950F et Carat, CBR 1000 F 89-92,VFR 1000 89, ST 1100 PAN EUROPEAN 90-, ST 1100 ABS-TCS 92-95, VT 1100C 94-96 + C2 + C3, GL 1500 F6 96-, <b>BUELL</b> 500 Blast 01-, <b>TRIUMPH</b> 800 Bonneville 01-, 900 Adventurer 96- et Legend TT 99- et Thunderbird 96-, Tiger 900 + 955	<b>2256</b>	U
	<b><u>WARNING : 2256R : ABSOLUTELY PROHIBITED ON THE ROAD</u></b>	<b><u>2256R</u></b>	UR
	<b>HONDA</b> CBR 1000 F, FP 93-	<b>2257</b>	W
	<b>SUZUKI</b> GSXR 400 R, GSXR 600, GSXR 750 89-93, GSX1100 F, GSX 1100 G, GSXR 1100 K-N, GSF1200Bandit 95-96 <b>TRIUMPH</b> 600TT 00-, Daytona 750, 900, 955, 1000, 1200, 900 +955 S.Triple, Trophy, T595, T509, 900 et 1200 Trophy, 955 Sprint BREMBO 4 piston calipers, <b>BIMOTA</b> all types since 89 <b>DUCATI</b> all types since 89 <b>GUZZI</b> V10 Centauro, California EV, Spécial, Daytona, 1100 sport <b>YAMAHA</b> 600YZF, 750 FZR R 89-, 750YZFOW02, 1000 YZF 96-, 600+1000 FZS Fazer, 1300 FJR 01-, 1300 XJR 99-	<b>2361</b>	V
	<b><u>WARNING : 2361R : ABSOLUTELY PROHIBITED ON THE ROAD</u></b>	<b><u>2361R</u></b>	VR
	<b>BREMBO</b> 2 pin caliper <b>DUCATI</b> 944 ST2, 916 ST4, 996, 748R, 750SS 98-, 900SS 98-, 600+750+900+916 Monster <b>HUSQVARNA</b> 610 SM, LT <b>CAGIVA</b> 650 + 1000 Raptor <b>SUZUKI</b> 1200 GSX 99- <b>APRILIA</b> 250RS 97-, RSV1000, RST 1000 Futura <b>GUZZI</b> V11 sport, 1100 California <b>BENELLI</b> 900Tornado 3 <b>BIMOTA</b> 900 DB4, 1000R SB8	<b>2539</b>	V
	<b>HONDA</b> CBR1100XX , CB 1100Hornet, CB1100X-11, VFR800, GL1800 Gold Wing	<b>2602</b>	U
	<b>KAWASAKI</b> KR-1 250S, ZX-R 400, ZX-4 400, ZZR-400,GPZ 500 93-, 600ZX6RZZR 600, ZX 750R, ZXR 750R, GPZ 900R 90-, ZX-9R 900, ZZR 1000, ZR 1100 Zephyr, ZZR 1100, <b>SUZUKI</b> RG 125F, RGV 250K-Gamma, GSF 400 Bandit 93,GSX 400S, GSXR 400 88-89, 600 GSXR 96-, 750 GSXR 00-, 1000TL <b>BERINGER 4 PISTON CALIPERS (2 pads)</b> <b><u>WARNING : 2654R2 : ABSOLUTELY PROHIBITED ON THE ROAD</u></b>	<b>2654</b>  <b>2654R 2</b>	U  V
	<b>BERINGER 6 PISTON CALIPERS (6 pads)</b> <b>BERINGER 2 PISTON CALIPERS (2 pads)</b> <b><u>WARNING : 2547R : ABSOLUTELY PROHIBITED ON THE ROAD</u></b>	<b>2547</b> <b>2547</b> <b><u>2547R</u></b>	VR AA XR
	<b>HONDA</b> 600CBR 99-, 600 CBR F4S 01-, 900CBR 98-, 1000 VTR SP1 00-	<b>2711</b>	V
	<b>BERINGER AEROTEC® 6 PISTON CALIPERS</b> sport riding on normal roads, competition occasionnally <b>BERINGER AEROTEC® 6 PISTON CALIPERS only for competition (PADS PROHIBITED ON THE ROAD)</b>	<b>1100 S</b> <b>1100R2</b>	Y Z
	<b>BERINGER ENDURANCE AEROTEC® 6 PISTON CALIPERS (2 pads 12mm thick)</b> <b>only for competition (PADS PROHIBITED ON THE ROAD)</b>	<b>1100R-</b> Depending on the develop- ment	YR
	<b>BERINGER RADIAL 4 PISTON AEROTEC® CALIPERS</b> <b>only for competition (PADS PROHIBITED ON THE ROAD)</b>	<b>1200S</b> <b>1200R2</b>	Y Z
	<b>FTE RADIAL 4 PISTON CALIPERS only for competition (PADS PROHIBITED ON THE ROAD)</b>	<b>1220R2</b>	ZR

The letter **R** means **RACING** quality. Pads with this letter R in their part number are **ABSOLUTELY PROHIBITED ON THE ROAD. Their using is ONLY FOR COMPETITION.**



# SPARE PARTS

CALIPERS	contents	price
Repair kit for 6P or 4P radial caliper	Pistons, all seals, screws, pad guides, bleeder	AH
Repair kit for 4P caliper	Pistons, all seals, screws, pad axle, bleeder	AJ
Overhaul of caliper	Disassembling, checking, new parts if necessary, assembling, test	AH
MASTER CYLINDERS		
Repair kit for master cylinder BR12 or BR16	All the parts except the aluminium parts	MCK
Overhaul of master cylinder BR12 or BR16	Disassembling, checking, new parts if necessary, assembling, test	MCK
Repair kit for MC 12.7	2 cup seal, dust seal, anti rollover ring	AA
Overhaul of master cylinder MC 12.7	Disassembling, checking, new parts if necessary, assembling, test	AA
Lever for BR12, BRO-12, CR12, BRO-10, CRO-9	Original one (with finger grips BR or plain lever BRO)	WR
Lever for BR16, CR16	Original one (with finger grips)	WR
Long lever for BR16, CR16	Long plain lever	AK
Reservoir cap	Engraved solid aluminium reservoir cap	AU
DISCS		
AERONAL hub (flat)	Aluminium hub, floaters, washers, snap rings	DA
AERONAL hub (with offset)	Aluminium hub, floaters, washers, snap rings	AL
Classic hub	Aluminium hub, floaters, washers, snap rings	AL
Floaters kit (for AERONAL disc)	6 floaters, 6 washers, 6 snap rings	AM
Floaters kit (for Classic disc)	12 floaters, 12 washers, 12 snap rings	FB
External rotor (for AERONAL disc)	Plain cast iron rotor	AO
External rotor (for Classic disc)	Cast iron rotor with holes	AO
SERVICES		
New colour on disc hub	New anodizing	AI
New colour on caliper	New anodizing	AE

BMW

**Part n° and prices**

BMW

MOTORBIKE	6 P. CALIPER			4P. CALIPER		
	Part n°		Price	Part n°		Price
	right	left		right	left	
BMW R and K Ø285 AV	B01	B11	P	4B01	4B11	S
BMW K1100, K1, Ø305, R1100R, RS, RT	B01	B11	P	4B01	4B11	S
BMW R1100S, GS	B01	B11	P	4B01	4B11	S
BMW R1200C, 850C	B01	B11	P	4B01	4B11	S
BMW K1200RS	B01	B11	P	4B01	4B11	S
BMW types 2001-	B02A	B12A	P			

**REPLACING KIT for BMW ORIGINAL NUTS**  
(12 floaters, 12 washers, 12 snap rings) in low friction steel for long life

PRICE : FA

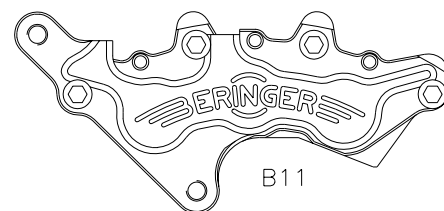

B11

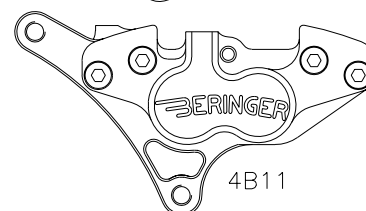

4B11

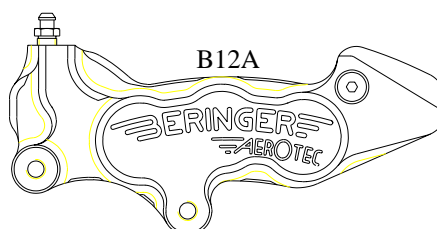

B12A

**CAUTION:** the range of BERINGER 6 piston calipers is in constant improvement due to the technological advance. BERINGER reserves the right to deliver AEROTEC® 6 piston calipers using BERINGER patents instead of standard 6 piston calipers, and without any extra price.

MOTORBIKE	FRONT DISC			6P. CALIPER (A means AEROTEC®)		4P. CALIPER		4P RADIAL AEROTEC® CALIPER		SINTERED PADS for original caliper		
	Part n°	Price		Part n°	Price	Part n°	Price	Part n°	Price	Part n°	Price	
		classic	AERONAL									right
125 RS	HONDA 10	D	F	D01		O	4D01		R			
125 RS 04-05	HONDA 10	D	F							4R01A	P	
250 RS	HONDA 10	D	F	D01	D11	O	4D01	4D11	R			
400XR	HONDA 16	C	EL		XRA	P		4XR	S			
250/500 CR -94 Ø310	HONDA 16 + bracket H001 for D11A	H	E		D11	O		4D11	R			
250/500 CR 95-03 Ø310	HONDA 8		EL		XR	P		4XR	S			
250/500 CR 04- Ø310	HONDA 8		EL		H15	P		4H15	S			
500CB	HONDA 2				H12	P			R			
500CBF 04-05	HONDA 2			H02A		P						
600 Hornet -05	HONDA 10	D	F	H02A H12A with washers		P	4H02	4H12 with washers	R			2256
600 CBF 04-05	HONDA 2			H02A	H12A	P						
600CBR 95-98	HONDA 10	D	F	H02A	H12A	P	4H02	4H12	R			2256 U
600CBR -99	HONDA 5		F	H01A	H11A	P	4H01	4H11	R			2711 V
600CBR RR 03-	HONDA 18		F	H01A	H11A	P	4H01	4H11	R			
600CBR RR 04-05	HONDA 18		F	H01A	H11A	P						
600 CBR F-FS 01-02	HONDA 13		F	H01A	H11A	P	4H01	4H11	R			2711 V
600 CBR F-FS 04-05	HONDA 13		F	H01A	H11A	P						
600XR 650XR Ø310	HONDA 16	C	EL		XRA	P		4XR	S			
650 NTV Deauville	HONDA 2			H02A	H12A	P	4H02	4H12	R			
650 NTV Revere	HONDA 9	C			H12A	P		4H12	R			2256 U
750 Seven Fifty	HONDA 2			H02A	H12A	P	4H02	4H12	R			2256 U
750 VFC	HONDA 9	C			H12A	P		4H13	R			2256 U
750 VFR 89-93	HONDA 2			H02A	H12A	P	4H02	4H12	R			2256 U
750 VFR 94-	HONDA 10	D	F	H02A	H12A	P	4H02	4H12	R			2256 U
800 VFR	HONDA 5		F									2602 F+R U
900 CBR -93	HONDA 5		F	H01A	H11A	P	4H01	4H11	R			2245 V
900 CBR 94-97	HONDA 10	D	F	H01A	H11A	P	4H01	4H11	R			2245 V
900 CBR RR 98-99	HONDA 4		F	H01A	H11A	P	4H01	4H11	R			2711 V
900 CBR 00- (Ø330)				H01A	H11A	P	4H01	4H11	R			2711 V
900 Hornet 02-	HONDA 13		F	H01A	H11A	P	4H01	4H11	R			
1000 CBR 89-92	HONDA 2			H02A	H12A	P	4H02	4H12	R			2256 U
1000 CBR RR 04-05	HONDA 18		F							4R01A	4R11A	P
1100 VT Shadow ACE 95	HONDA 9	C			H12A	P		4H12	R			2256 U
1000 VTR	HONDA 10	D	F	H01A	H11A	P	4H01	4H11	R			2245 V
1000 VTR F 04-05	HONDA 10	D	F	H01A	H11A	P						
1000 VTR SP1	HONDA 14		F	H01A	H11A	P	4H01	4H11	R			2711 V
1000 VTR SP2 04-05	HONDA 14		F	H01A	H11A	P						
1000 Varadero 99-	HONDA 5		F									2602 U
1100 ST Pan European	HONDA 9	C										(-95) : 2256 U (96-) : 2602
1100 CBR XX -98	HONDA 3		F									2602 U
1100 CBRXX 99-	HONDA 7		F									2602 U
1300 CB 04-05	HONDA 18		F	H01A	H11A	P						
1500 F6C	HONDA 5		F	H02A	H12A	P	4H02	4H12	R			2256 U

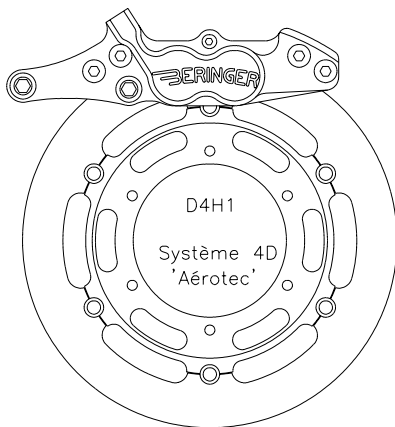

CAUTION: the range of BERINGER 6 piston calipers is in constant improvement due to the technological advance. BERINGER reserves the right to deliver AEROTEC® 6 piston calipers using BERINGER patents instead of standard 6 piston calipers, and without any extra price.

**AERONAL DISCS**

HONDA 5 et 10  
Aéronal

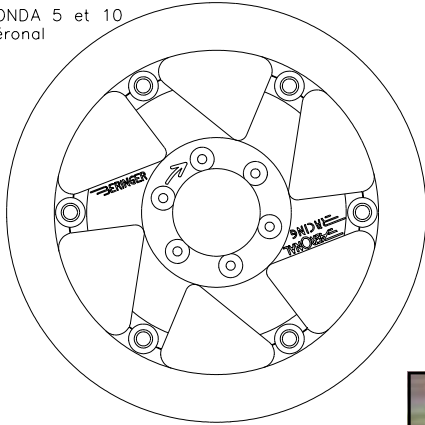

HONDA 6  
Aéronal

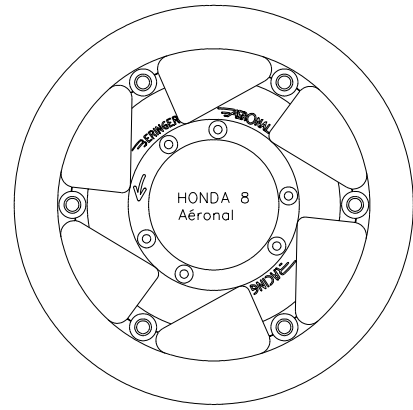
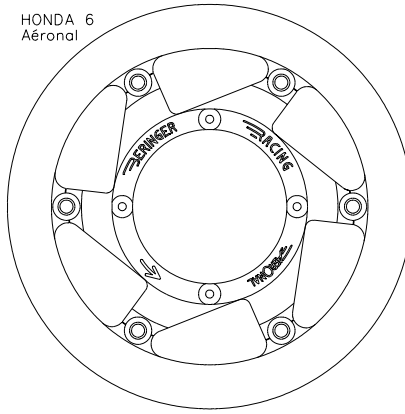

HONDA 8  
Aéronal

**CLASSIC DISCS**

HONDA 6  
Classic

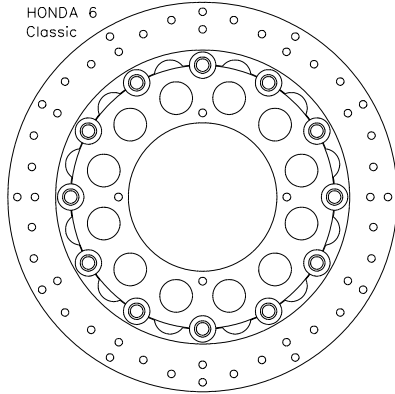

4D System



**AEROTEC® 6 PISTON CALIPERS**

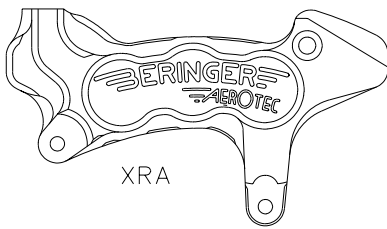

XRA

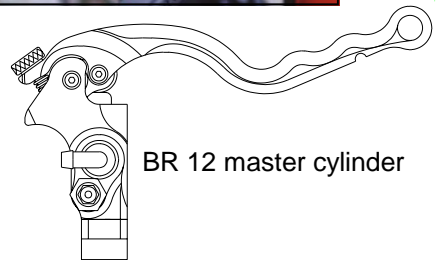

BR 12 master cylinder

**AEROTEC® RADIAL 4P CALIPERS**

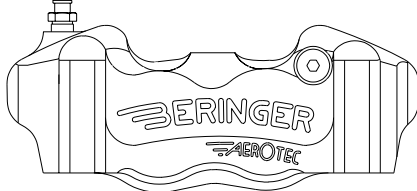

**4 PISTON CALIPERS**

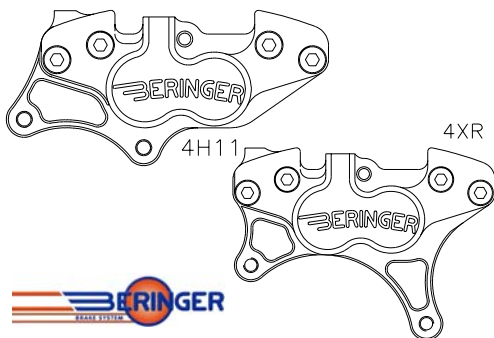

4H11

4XR



**2 PISTON CALIPER**



GP French team

MOTORBIKE	FRONT DISC			6P. CALIPER (A means AEROTEC®)			4P. CALIPER			4P RADIAL AEROTEC CALIPER			SINTERED PADS for original caliper	
	Part n°	Price		Part n°		Price	Part n°		Price	Part n°		Price	Part n°	Price
		classic	AERONAL	right	left		right	left		right	left			
400 Bandit	SUZUKI 5	D	F										93 : 2654	U
400 DR	SUZUKI 10		EL		XRA	P		4XR	S					
450 RMZ	SUZUKI 13		EL		XRA	P		4XR	S					
500 GSE	SUZUKI 5	D	F	S02A		P								
600 Bandit GSF	SUZUKI 1		F	S02A	S12A	P								
600 GSX-F	SUZUKI 1		F	S02A	S12A	P								V
600 DR Ø300	SUZUKI 7	C												
600 GSXR 96-	SUZUKI 9	D	EL	S01A	S11A	P	4S01	4S11	S				2654	U
600 GSXR 01- 03	SUZUKI 9	D	EL	H01A	H11A	P	4H01	4H11	R				2361	V
600 GSXR 04-05	SUZUKI 12		EL							4R01A	4R11A	P		
650 Bandit -05	SUZUKI 1		F	S02A	S12A	P								
650 SV -02	SUZUKI 1		F	S02A	S12A	P								
650 SV 03-05				S02A	S12A	P								
650 XF Freewind	SUZUKI 7	C												
750 GSX				S02A	S12A	P								
750 GSX-F -05	SUZUKI 1		F	S02A	S12A	P								
750 GSXR 89-	SUZUKI 6	D	F	S01A	S11A	P	4S01	4S11	S				(-93) : 2361	V
750 GSXR 96-	SUZUKI 9	D	EL	S01A	S11A	P	4S01	4S11	S				(94-) : 2255	W
750 GSXR 2000- 03	SUZUKI 9	D	EL	H01A	H11A	P	4H01	4H11	R				2654	U
750 GSXR 04-05	SUZUKI 12		EL							4R01A	4R11A	P		
800 DR 90-	SUZUKI 7	C												
800 Intruder	SUZUKI 8	C		HD01+ S001 (bracket)		SR	4HD01+S001 (bracket)		M					
800 VZ Marauder				S02A		P								
1000 GSXR 01- 02	SUZUKI 9	D	EL	H01A	H11A	P	4H01	4H11	R				2255	W
1000 GSXR 03-04	SUZUKI 12		EL							4R01A	4R11A	P		
1000 GSXR 05	SUZUKI 14		EL							4R01A	4R11A	P		
1000 SV -05	SUZUKI 11		EL	H01A	H11A	P	4H01	4H11	R					
1000 V Strom 05	SUZUKI 11		EL	S02A	S12A	P								
1000TL S-R	SUZUKI 9	D	EL	S01A	S11A	P	4S01	4S11	S				S=2654 R= 2255	U W
GS 1100G				K01A	K11A	P	4K01	4K11	R					
1100 GSXKatana				S01A	S11A	P	4S01	4S11	S				2361	V
1100 GSXR 90-	SUZUKI 6	D	F	S01A -88	S11A -88	P	4S01 -88	4S11-88	S				(-92) : 2361 (93-) : 2255	U W
1200 Bandit	SUZUKI 5	D	F	S01A	S11A	P	4S01	4S11	S				(-01) : 2361 (01-) : 2255	V W
1300 GSXR 99-	SUZUKI 9	D	EL	S01A	S11A	P	4S01	4S11	S				2255	W
1300 Hayabusa 05	SUZUKI 9	D	EL	S01A	S11A	P								
1400 GSX 03-04	SUZUKI 9	D	EL	S01A	S11A	P	4S01	4S11	S					
1400 GSX 05	SUZUKI 9	D	EL	H01A	H11A	P								
1400 GSXR 01-	SUZUKI 9	D	EL	H01A	H11A	P	4H01	4H11	R					
1400 Intruder	SUZUKI 8	C		HD01+ S001			4HD01+S00 1 (bracket)		M					



CAUTION: the range of BERINGER 6 piston calipers is in constant improvement due to the technological advance. BERINGER reserves the right to deliver AEROTEC® 6 piston calipers using BERINGER patents instead of standard 6 piston calipers, and without any extra price.

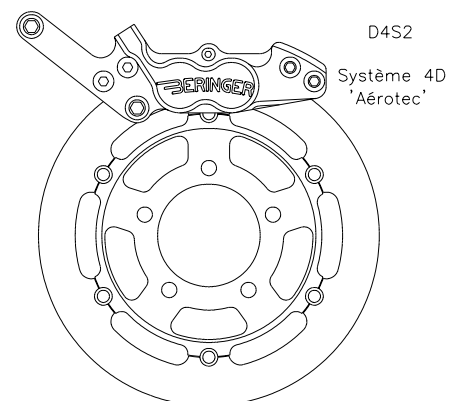

**AERONAL DISCS**

SUZUKI 9 Aéronal

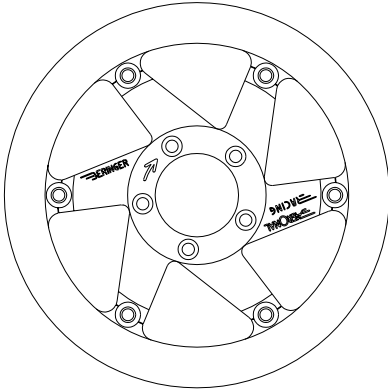

**CLASSIC DISCS**

SUZUKI 9 Classic

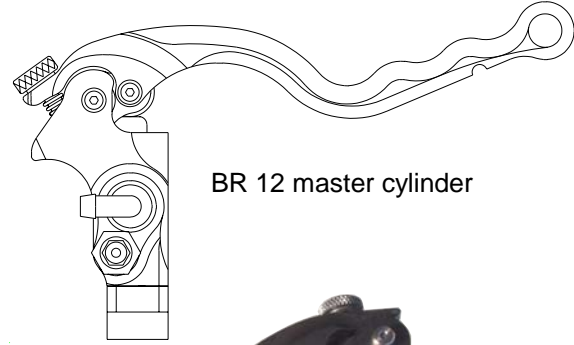
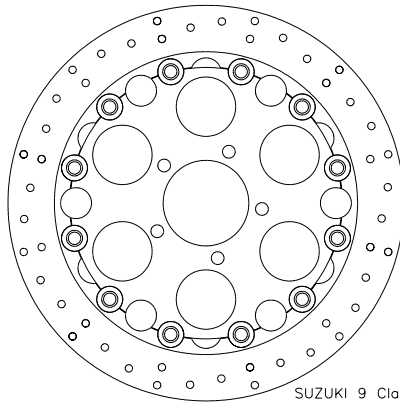

BR 12 master cylinder



CR16

**AEROTEC® 6 PISTON CALIPERS**

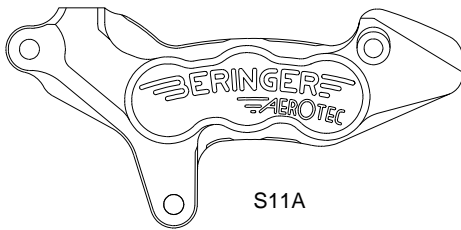

S11A



CAUTION: the range of BERINGER 6 piston calipers is in constant improvement due to the technological advance. BERINGER reserves the right to deliver AEROTEC® 6 piston calipers using BERINGER patents instead of standard 6 piston calipers, and without any extra price.

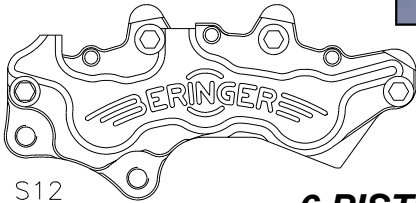

S12

**6 PISTON CALIPERS**

**AEROTEC® RADIAL 4P CALIPERS**



**4 PISTON CALIPERS**

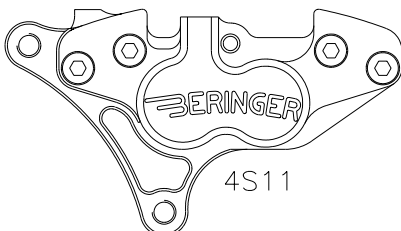

4S11



Zongshen



Phase One Endurance

MOTORBIKE	FRONT DISC			6P. CALIPER (A means AEROTEC®)			4P. CALIPER			4P. RADIAL AEROTEC CALIPER			SINTERED PADS for original caliper	
	Part n°	Price		Part n°	Price	Part n°	Price	Part n°	Price	Part n°	Price	Part n°	Price	
		classic	AERONAL											right
250 TDR	YAMAHA 7	C	EL		Y11A	P		4Y11	S					
250 TZR	YAMAHA 7	C	EL		Y11A	P		4Y11	S			89-92 : 2361	V	
250 WRF and YZ Ø310	HONDA 16		EL		XRA			4XR	S					
400WRF 310	HONDA 16		EL		XRA			4XR	S					
426 YZ Ø310	HONDA 16		EL		XRA			4XR	S					
535 XV Virago	YAMAHA 8	C	EL											
600 R6 99- 02	YAMAHA 8	C	EL	Y01A	Y11A	P	4Y01	4Y11	S			2361	V	
600 R6 03-04	YAMAHA 10		EL	Y01A	Y11A	P	4Y01	4Y11	S					
600 R6 2005	YAMAHA 12		EL							4R01A	4R11A	P		
600 Diversion 98-	YAMAHA 8	C	EL											
600 XT(E) Ø310 + bracket for original caliper	YAMAHA 4 + bracket Y006 years 90-94 YAMAHA 4 + bracket Y005 years 95-03		O											
600 XJ	YAMAHA 8	C	E	Y01A	Y11A	P								
600 FZ6, FZ6 Fazer -05	YAMAHA 10		EL	Y02A	Y12A	P								
600 FZR	YAMAHA 3	C		Y01A	Y11A	P	4Y01	4Y11	S			90- : 2253	U	
600 FZX Fazer 98-	YAMAHA 3	C		Y01A	Y11A	P	4Y01	4Y11	S			2361	V	
600 YZF	YAMAHA 8	C	E	Y01A	Y11A	P	4Y01	4Y11	S			2361	V	
650 XVS Drag Star	YAMAHA 8	C	E											
660 SZR	YAMAHA 7	C	E	D01		O	4D01		R			2361	V	
660 TX 04-				D02	D12	P	← with screws M10-30x1.5 or M10-35x1.5							
660 XTR 04-	YAMAHA 8	C	E	S02A	S12A	P	← with spacers 10x20x4 and screws M10-40x1.25							
750 FZR	YAMAHA 3	C		Y01A	Y11A	P	4Y01	4Y11	S			87-88 : 2253	U	
750 FZR OW01				S01A	S11A	P	4S01	4S11	S					
750 YZF	YAMAHA 7	C	E	Y01A	Y11A	P	4Y01	4Y11	S			2254	W	
750 YZF R7 OW 02				S01A	S11A	P	4S01	4S11	S					
850 TDM	YAMAHA 3	C		Y01A	Y11A	P	4Y01	4Y11	S			2253	U	
850 TRX	YAMAHA 3	C		Y01A	Y11A	P	4Y01	4Y11	S			2253	U	
900 TDM 02-05	YAMAHA 8	C	E	Y01A	Y11A	P								
1000 FZR	YAMAHA 7	C	E	Y01A	Y11A	P	4Y01	4Y11	S			87-90 : 2253 94- : 2254	U W	
1000 FZS Fazer	YAMAHA 8	C	E	Y01A	Y11A	P	4Y01	4Y11	S			2361	V	
1000 YZF -96	YAMAHA 8	C	E	Y01A	Y11A	P	4Y01	4Y11	S			2361	V	
1000 YZF R1 97-03	YAMAHA 8	C	E	Y01A	Y11A	P	4Y01	4Y11	S			2361	V	
1000 YZF R1 04-05	YAMAHA 11		EL							4R01A	4R11A	P		
1100 BT Bulldog	YAMAHA 8	C	E	Y01A	Y11A	P	4Y01	4Y11	S			2361	V	
1100 XVS Drag Star	YAMAHA 8	C	E	Y02A	Y12A	P	4Y02	4Y12	S					
V MAX 93 -	YAMAHA 8	C	E	Y01A	Y11A	P	4Y01	4Y11	S			2253	U	
1200 XJR	YAMAHA 7	C	E	Y01A	Y11A	P	4Y01	4Y11	S			2253	U	
1200FJ 88-	YAMAHA 3	C		Y01A	Y11A	P	4Y01	4Y11	S			2253	U	
1300 FJR- XJR	YAMAHA 8	C	E	Y01A	Y11A	P	4Y01	4Y11	S			2361	V	
1300 FJR 03-05	YAMAHA 6	C	E	Y01A	Y11A	P	4Y01	4Y11	S					
1300 XVZ Royal Star	YAMAHA 8	C	E	Y01A	Y11A	P	4Y01	4Y11	S			2253	U	
MT 01	YAMAHA 11		EL							4R01A	4R11A	P	2253	U

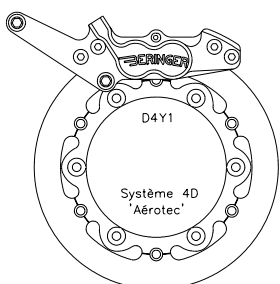

**CAUTION:** the range of BERINGER 6 piston calipers is in constant improvement due to the technological advance. BERINGER reserves the right to deliver AEROTEC® 6 piston calipers using BERINGER patents instead of standard 6 piston calipers, and without any extra price.

**AERONAL DISCS**

YAMAHA 8 Aéronal

YAMAHA 7 Aéronal

YAMAHA 9 Aéronal

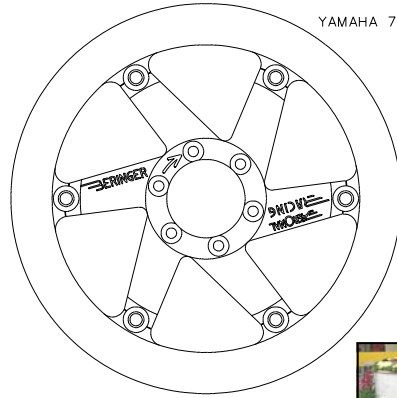
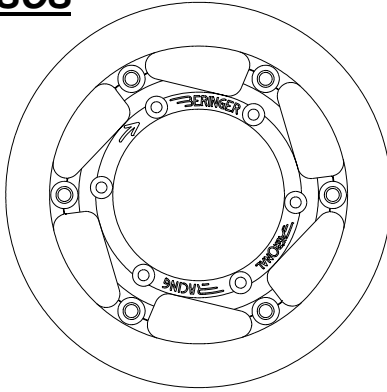
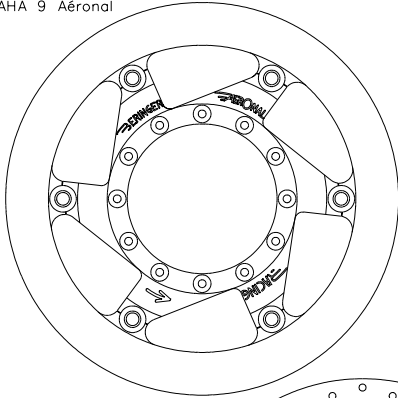

**CLASSIC DISCS**

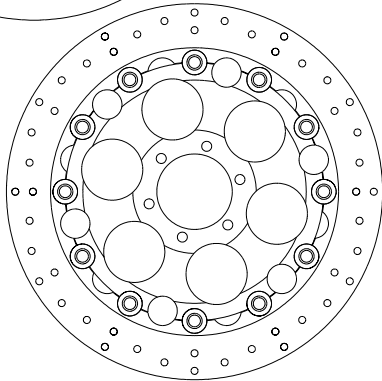

YAMAHA 7 Classic



**AEROTEC® 6 PISTON CALIPERS**

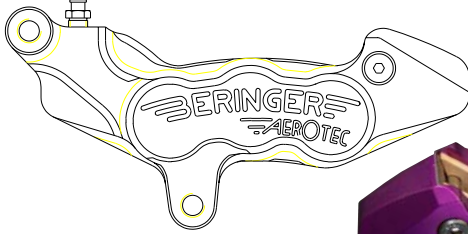

**AEROTEC® RADIAL 4P CALIPERS**

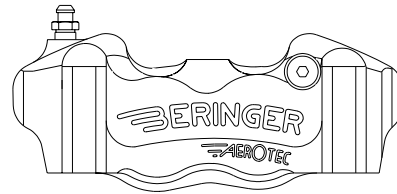

**6 PISTON CALIPERS**

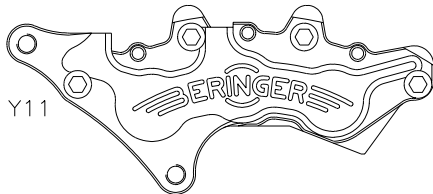

Y11



**2 PISTON CALIPER**

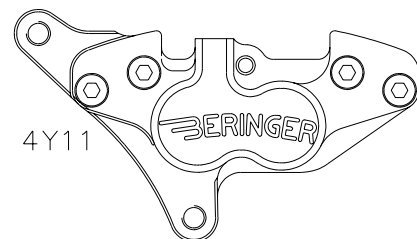

4Y11



**4 PISTON CALIPERS**



MOTORBIKE	FRONT DISC			6P. CALIPER (A means AEROTEC®)			4P RADIAL AEROTEC CALIPER				SINTERED PADS for original caliper			
	Part n°	Price		Part n°		Price	Part n°		Price	Part n°		Price	Part n°	Price
		classic	AERONAL	right	left		right	left		right	left			
250 KX + KXF 94-	KAWA 11		EL		XR	P		4XR	S					
600 ZZR	KAWA 3		F	K01	K11	P			R				2654	U
600 ZX 6R -02	KAWA 3		F	S01	S11	P			R				2654	U
600 ZX 6R 03-05	KAWA 12	(with spacers)	F							4R01A	4R11A	P		
650 KLXR Ø320	KAWA 8	C												
650W	KAWA 3		F	S02A		P								
750 Z 04-05	KAWA 3		F	S02A	S12A	P								
750 ZR-7 -04	KAWA 3		F	S02A	S12A	P								
750 ZXR	KAWA 4	C	F	K01	K11	P							2654	U
750 ZXRR	KAWA 5	D	F	K01	K11	P							2654	U
750 ZXR 93-	KAWA 5	D	F	K01	K11	P							2654	U
750 ZX7 R and RR 96-	KAWA 5	D	F	S01	S11	P							2255	W
750 Stinger	KAWA 4	C	F	K01	K11	P							2654	U
750 Zephyr	KAWA 3		F											
800 VN	KAWA 10	C												
900 ZX9R Ninja -96	KAWA 5	D	F	K01	K11	P							2654	U
900 ZX9R 96-97	KAWA 5	D	F	S01	S11	P							2255	W
900 ZX9R 98-	KAWA 3		F	S01	S11	P							2255	W
900 ZX9R 2000-01	KAWA 4	C	F	S01	S11	P							2255	W
900 ZX9R 2002	KAWA 5	D	F	H01A	H11A	P	4H01	4H11	R					
1000 GTR 95-	KAWA 3		F	K01	K11	P							2654	U
1000 Z -05	KAWA 3			H01A	H11A	P	4H01	4H11	R					
1000 ZX10R 03-	KAWA 3		F							4R01A	4R11A	P		
1000 ZX10R 04-05	KAWA 13		EL							4R01A	4R11A	P		
1100 ZZR -93	KAWA 4	C	F	K01	K11	P								
1100+1200 ZRX 97-	KAWA 4	C	F	S01	S11	P							2255	W
1100 ZZR 93-	KAWA 5	D	F	K01	K11	P							2654	U
1100 Zephyr	KAWA 4	C	F	K01	K11	P							2654	U
1200 ZZR 02-05	KAWA 5	D	F	H01A	H11A with spacers	P	4H01A	4H11 with spacers	R					
1200ZRX 04	KAWA 4	C	F	H01A	H11A	P								
1200ZRX 05	KAWA 4	C	F	S01	S11	P								
ZX12R -03	KAWA 5	D	F	S01	S11	P								
ZX12R 04-05	KAWA 5	D	F							4R01A	4R11A	P		
1500VN 95-96	KAWA 10	C												

**AERONAL DISCS**

**CLASSIC DISCS**

Diameters of the discs :  
KAWA 3 : Ø300  
KAWA 4 : Ø310  
KAWA 5 : Ø320

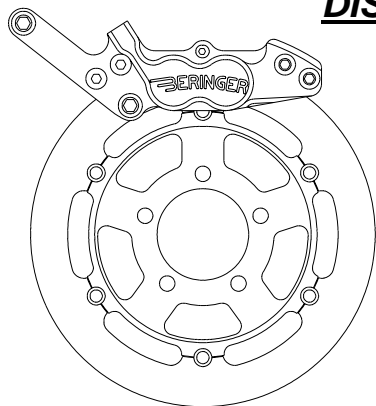

Système 4D 'Aérotec'

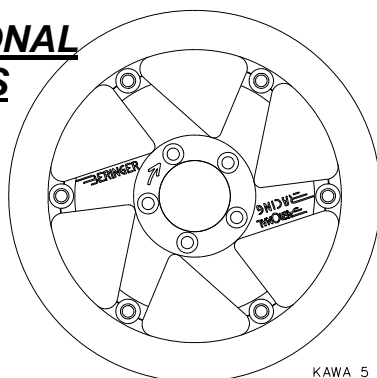

KAWA 5 Aeronal

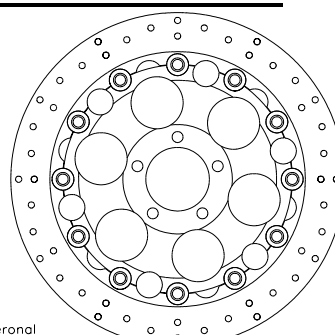

KAWA 5 Classic

CAUTION: the range of BERINGER 6 piston calipers is in constant improvement due to the technological advance. BERINGER reservest he right to deliver AEROTEC® 6 piston calipers using BERINGER patents instead of standard 6 piston calipers, and without any extra price.

**4 PISTON CALIPERS**

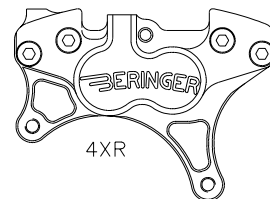

4XR

**AEROTEC® 6 PISTON CALIPERS**

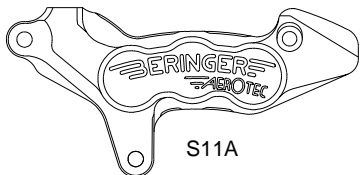

S11A

**AEROTEC® RADIAL 4P CALIPER**

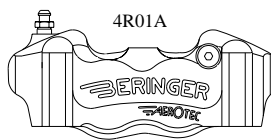

4R01A

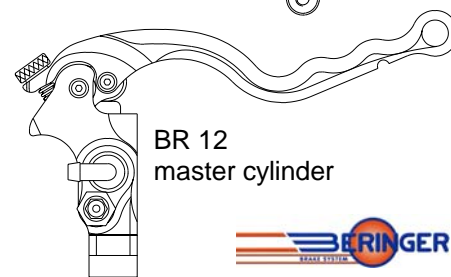

BR 12 master cylinder



MOTORBIKE	FRONT DISC			6P. CALIPER (A means AEROTEC®)		4P. CALIPER		4P. RADIAL AEROTEC CALIPER		SINTERED PADS for original caliper		
	Part n°	Price		Part n°	Price	Part n°	Price	Part n°	Price	Part n°	Price	
		classic	AERONAL									right
AMERICA -05	TRIUMPH 5		F		H12A	P		4H12	R			
BONNEVILLE -05	TRIUMPH 5		F		H12A	P		4H12	R			
DAYTONA 650 04-05				S01	S11	P						
DAYTONA 955 02-05	TRIUMPH 7		F	T01	T11	P					2361	V
SPEED MASTER	TRIUMPH 5		F				4H02	4H12	R			
SPEED MASTER 04-05	TRIUMPH 5		F	H02A	H12A	P						
SPEED TRIPLE 02-04	TRIUMPH 7		F	T01	T11	P					2361	V
SPEED TRIPLE 05	TRIUMPH 7		F						4R01A	4R11A	P	
SPEED FOUR	TRIUMPH 6		F	T01	T11	P						
SPRINT ST	TRIUMPH 4		F	S01	S11	P					2361	V
SPRINT ST 04-05	TRIUMPH 7		F	S01	S11	P						
SPRINT RS	TRIUMPH 4		F	S01	S11	P					2361	V
ROCKET III 04-05	TRIUMPH 7		F	T01	T11							
THUNDER BIRD	TRIUMPH 3		F		H12A	P		4H12	R		2256	V
	HONDA 9	C			H12A	P		4H12	R			
T. BIRD SPORT	TRIUMPH 5		F				4H02	4H12	R			
TROPHY 1200	TRIUMPH 2	C		S01	S11	P					2361	V
TIGER 955 i (injection)	TRIUMPH 5		F				4H02	4H12	R		2256	U
TT600	TRIUMPH 6		F	T01	T11	P					2361	V
TRHUXTON 900 04-05	TRIUMPH 3		F		H12A	P						

**AERONAL DISCS**

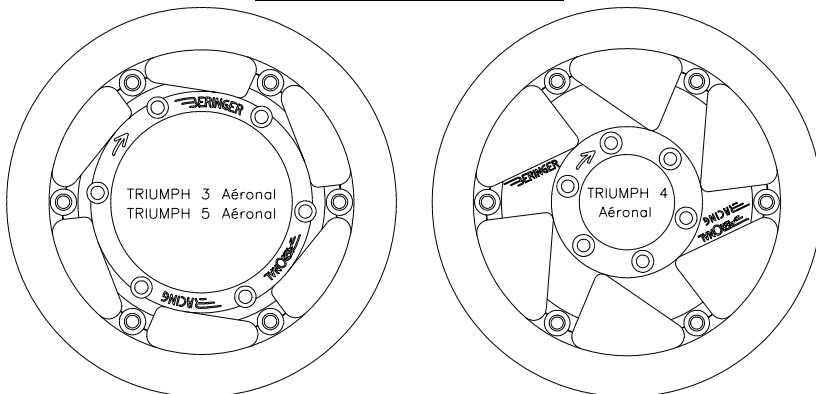

**CLASSIC DISCS**

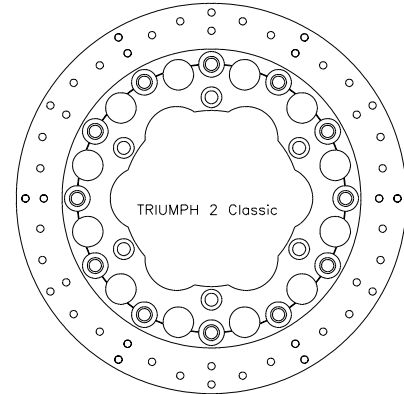

**AEROTEC® 6 PISTON CALIPERS**

CAUTION: the range of BERINGER 6 piston calipers is in constant improvement due to the technological advance. BERINGER reservest he right to deliver AEROTEC® 6 piston calipers using BERINGER patents instead of standard 6 piston calipers, and without any extra price.

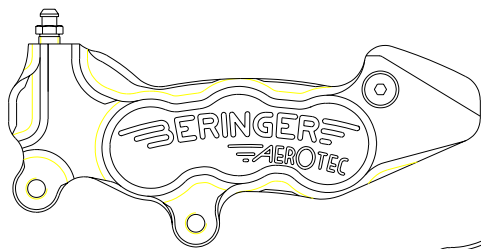

**6 PISTON CALIPERS**

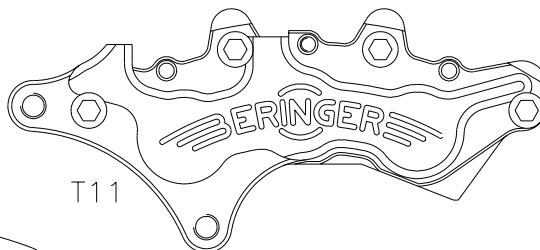

**4 PISTON CALIPERS**

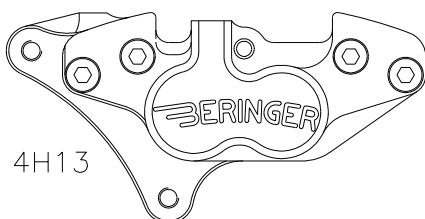

**RADIAL 4P CALIPER**

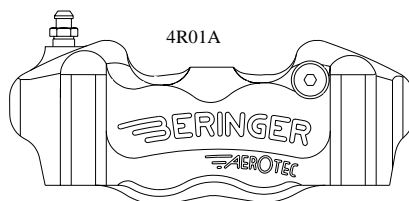

BR 16 master cylinder

BIMOTA CAGIVA DUCATI GUZZI VOXAN SHERCO  
DUKE HUSABERG HUSQVARNA KTM VERTEMATI VOR CCM

MOTORBIKE	FRONT DISC			6P. CALIPER (A means AEROTEC®)			4P. CALIPER		4P. RADIAL AEROTEC CALIPER		SINTERED PADS for original caliper	
	Part n°	Price		Part n°	Price	Part n°	Price	Part n°	Price	Part n°	Price	
		classic	AERONAL									right
APRILIA all types with calliper centre distances=65mm and 320mm disc can be equipped with the 4D AEROTEC system												
1000 FALCO SL	YAMAHA 7	C	EL	D02	D12	P						
1000 RSV R et Tuono	YAMAHA 7	C	EL	D02	D12	P						
1000 RSV Factory et Tuono Racing 04-05	YAMAHA 7	C	EL						4R02A	4R12A	P	
BENELLI TNT 1130	YAMAHA 7	C	EL	D02	D12	P						
Tornado 04-05	YAMAHA 7	C	EL						4R02A	4R12A	P	
BIMOTA 97-	YAMAHA 7	C	EL	D02	D12	P						2539 U
BIMOTA -97	YAMAHA 7	C	EL	D01	D11	O						U
CAGIVA 900 Elephant	HONDA 2	C										
DUCATI all types with calliper centre distances=65mm and 320mm disc can be equipped with the 4D AEROTEC system												
600 SS + 748 + 916 (entraxe fixation étrier=40mm)	YAMAHA 7	C	EL	D01	D11	O						89- : 2361 U
750 SS -97	YAMAHA 7	C	EL	D01	D11	O						2361 U
750 SS 98-	YAMAHA 7	C	EL	D02	D12	P						2539 U
851 et 888	YAMAHA 7	C	EL	D01	D11	O						89- : 2361 U
900 SS -96	YAMAHA 7	C	EL	D01	D11	O						89- : 2361 U
900 SS 97-	YAMAHA 7	C	EL	D02	D12	P						2539 U
916 à 998 et ST2 à ST4S (calliper center distance=65mm)	YAMAHA 7	C	EL	D02	D12	P						2539 U
996 Hyper Sport 99-	YAMAHA 7	C	EL	D02	D12	P						2539 U
Monstro 600 et 900	YAMAHA 7	C	EL	D01	D11	O						89- : 2361 U
749 et 999 04-05	DUCATI 1			D02	D12	P						
999 S 05	DUCATI 1		F						4R02A	4R12A	P	
1000 DS Supersport, Monster, Monster S,	YAMAHA 7	C	F	D02	D12	P						
GUZZI												
V11 sport + all types 04-05	YAMAHA 7	C	EL	D02	D12	P						2539 U
V10 Centauro GT/sport; California EV, special ; Daytona; 1100 sport	YAMAHA 7	C	EL	D01	D11	O						2361 U
VOXAN Roadster, Café R.	YAMAHA 7	C	EL	D01	D11	O						
HUSABERG 2000-	KT2		EL		KT13A	P		4KT13	S			
SM 05	KT2		EL							4R12A	P	
HUSQVARNA 2000-	HU1		EL		HU11A	P						
KTM enduro -1999	KT2		EL					4KT11	S			
enduro 2000-05	KT2		EL		KT13A	P		4KT13	S			
525 SMR 05	KT2		EL							4R12A	P	
DUKE 1 -98					D11	O		4D11	R			
Duke 2 99-	KT3		EL		D12	P						
990 Super Duke	YAMAHA 7	C	EL	D02	D12	P						
SHERCO	SHERCO 1		EL		HU11A	P						
VERTEMATI -2002	HONDA 8	C	EL		KT13A	P		4KT13	S			
VERTEMATI 2003-	HONDA 8		EL		XRA	P		4XR	S			
VOR	VO1		EL		HU11A	P						

CAUTION: the range of BERINGER 6 piston calipers is in constant improvement due to the technological advance. BERINGER reservest he right to deliver AEROTEC® 6 piston calipers using BERINGER patents instead of standard 6 piston calipers, and without any

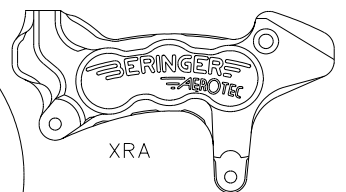
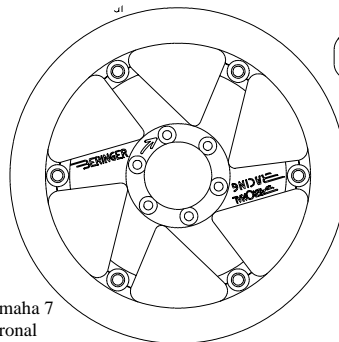
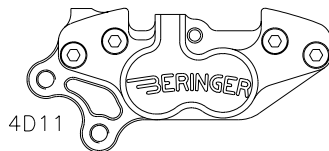
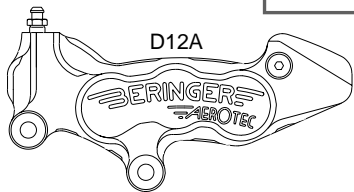

MOTORBIKE	CLASSIC DISC		AERONAL DISC		6 PISTON CALIPER			4 PISTON CALIPER		
	Part n°	Price	Part n°	Price	right	left	Price	right	left	Price
→ 1999 Ø291 original (11"5)	HD1	HA	HD1R_G (left) HD1R_D (right)	E	HD01	HD11	HD	4HD01	4HD11	HF
→ 1999 Ø320 (12"5)	HD2	HB	HD2R_G (left)	F	HD02	HD12	HE			
→ 1999 Ø254 (10")	HD3	HA						4HD03	4HD13	HF
2000- Ø291 types	HD4	HA	HD4R-G (left) HD4R-D (right)	E	HD04	HD14	HE			
<b>BUELL</b>			BU1	F				4HD03	4HD13	HF

This **BUELL** brake kit is made of : two front AERONAL BU1 discs Ø300 and two 4 piston calipers (4HD03 and 4HD13) delivered with sintered metal pads. The original master-cylinder is acceptable.

REAR BRACKETS for <i>BERINGER</i> 6 or 4 piston CALIPERS		
MOTORBIKE	Part n°	Price
Rear 1340 Softtail for HD11 or 4HD11	HD002	HI
Rear Dyna Glide for HD01 or 4HD01	HD003	HI
Rear Sportster for HD11 or 4HD11	HD004	HI
Rear Softtail for HD01 caliper up	HD005	HI
Type 2000 rear Softtail for HD01 or 4HD01	HD006	HI
Type 2000 rear Sportster for HD11 or 4HD11	HD009	HI
Type 2000 rear Dyna for HD01 or 4HD01	HD008	HI

All the calipers are delivered with the **BERINGER** sintered metal

**FINITION especially for HARLEY and BUELL :**

- **DISCS :** the hub is black or silver anodised, the cast iron rotor is silver
- **CALIPERS :** black or silver anodised

Other colours are available on orders with an extra price of **FA** per set of parts, with a 15 days delay.

**WARNING: The chrome plated finition** is available but with a delay and an extra price of **FB per part**: this covering is strictly reserved for an occasional use. Under no circumstances, water or corrosive products (like removal of snow salt) must not stay on the chrome plating. This would cancel the guarantee. In the same way, chips caused by fine gravel would invalidate the warranty to.

**The polished finition** is also available but with delay and an extra price of **AA per part**.

**ORIGINAL DIMENSIONS: 11.5 "**

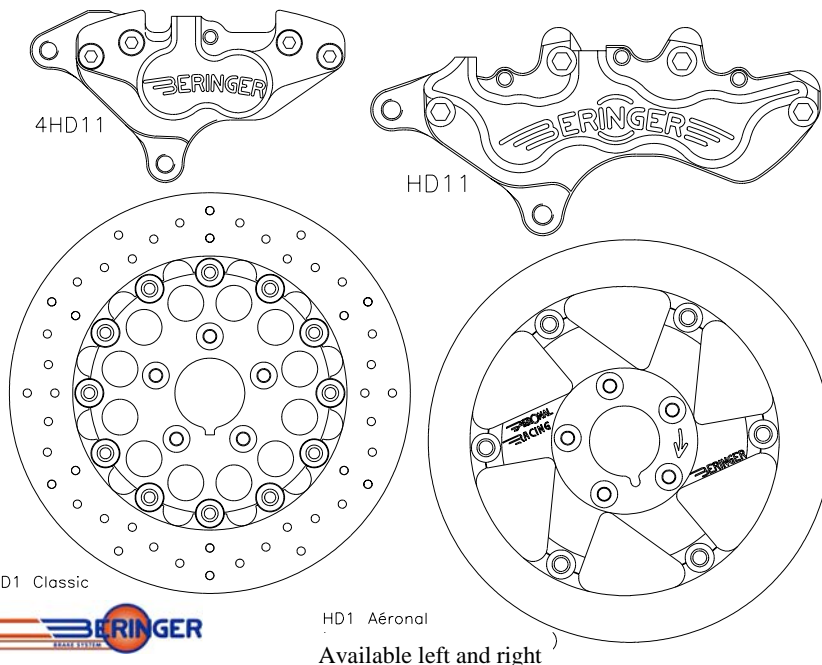

HD1 Classic

HD1 Aeronal

Available left and right

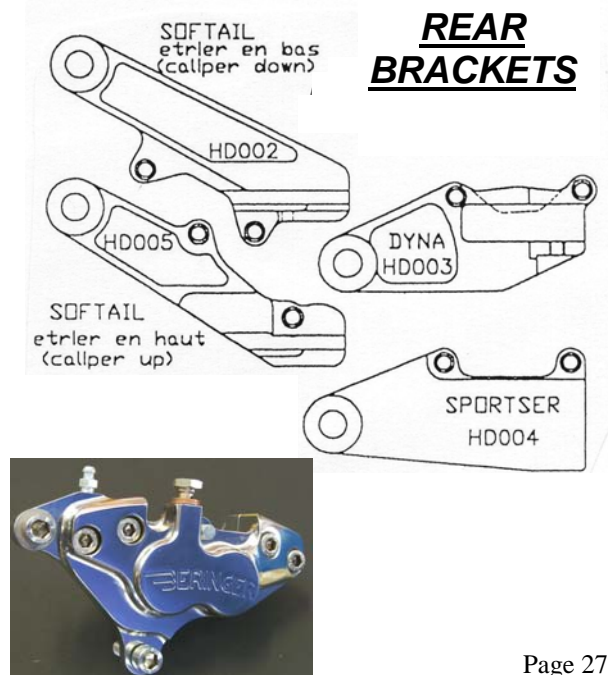

**REAR BRACKETS**

**DIMENSIONS : 10" = Ø254 = smaller diameter**

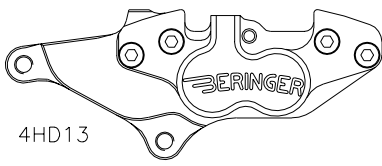

4HD13

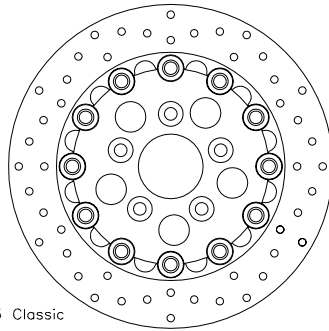

HD3 Classic

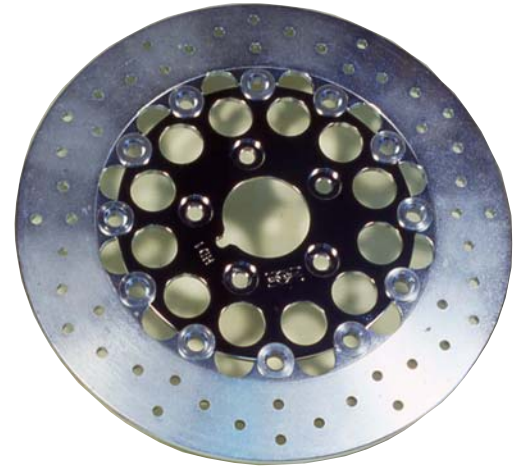

**DIMENSIONS : 12.6" = Ø320 = bigger diameter**

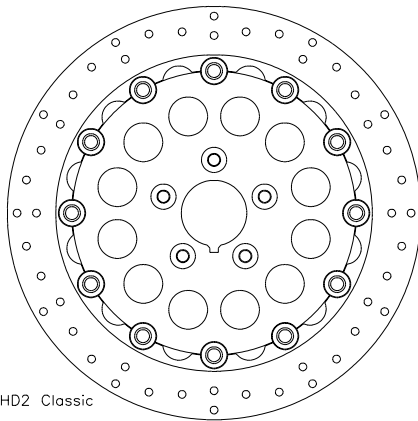

HD2 Classic

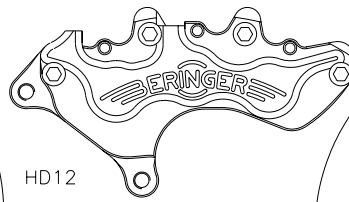

HD12

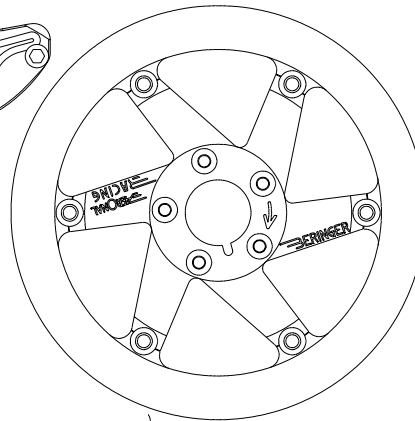

HD2 Aéronal

**2000 types : 11.5" = Ø291 = original diameter**

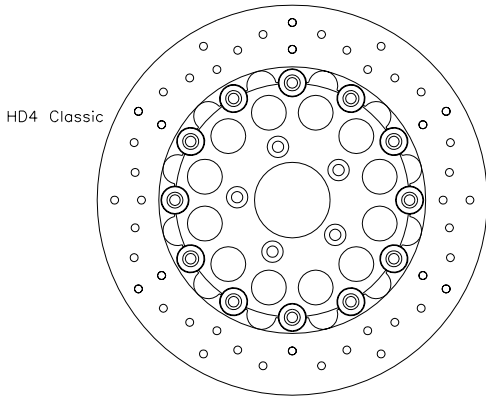

HD4 Classic

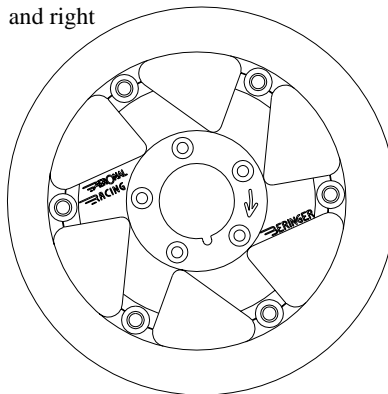

HD4 Aéronal  
Available left  
and right

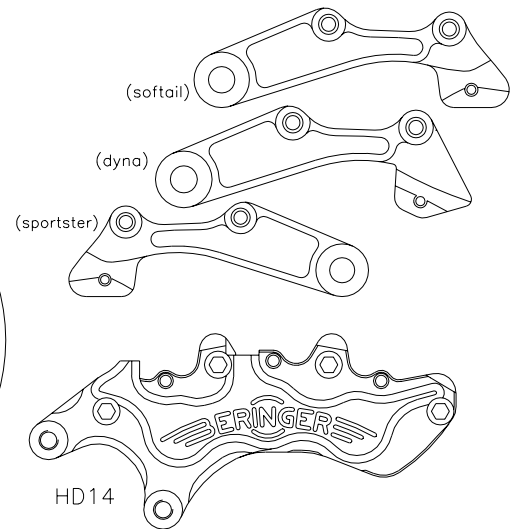

HD14



**KIT for BUELL**

4HD13  
Available left  
and right

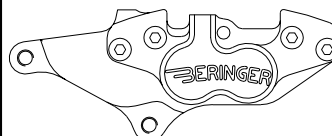

BU 1 Aéronal  
Available left  
and right

